



Standard Test Methods and Definitions for Mechanical Testing of Steel Products¹

This standard is issued under the fixed designation A 370; the number immediately following the designation indicates the year of original adoption or, in the case of revision, the year of last revision. A number in parentheses indicates the year of last reapproval. A superscript epsilon (ϵ) indicates an editorial change since the last revision or reapproval.

This standard has been approved for use by agencies of the Department of Defense. Consult the DoD Index of Specifications and Standards for the specific year of issue which has been adopted by the Department of Defense.

1. Scope

1.1 These test methods² cover procedures and definitions for the mechanical testing of wrought and cast steel products. The various mechanical tests herein described are used to determine properties required in the product specifications. Variations in testing methods are to be avoided and standard methods of testing are to be followed to obtain reproducible and comparable results. In those cases where the testing requirements for certain products are unique or at variance with these general procedures, the product specification testing requirements shall control.

1.2 The following mechanical tests are described:

	Sections
Tension	5 to 13
Bend	14
Hardness	15
Brinell	16, 17
Rockwell	18
Impact	19 to 28

1.3 Annexes covering details peculiar to certain products are appended to these test methods as follows:

	Annex
Bar Products	1
Tubular Products	2
Fasteners	3
Round Wire Products	4
Significance of Notched-Bar Impact Testing	5
Converting Percentage Elongation of Round Specimens to Equivalents for Flat Specimens	6
Testing Seven-Wire Stress-Relieved Strand	7
Reporting of Test Data	8
Methods for Testing Steel Reinforcing Bars	9
Procedure for Use and Control of Heat-Cycle Simulation	10

1.4 The values stated in inch-pound units are to be regarded as the standard.

1.5 When this document is referenced in a metric product specification, the yield and tensile values may be determined in inch-pound (ksi) units then converted into SI (MPa) units. The elongation determined in inch-pound gage lengths of 2 or 8 in. may be reported in SI unit gage lengths of 50 or 200 mm, respectively, as applicable. Conversely, when this document is referenced in an inch-pound product specification, the yield and tensile values may be determined in SI units

then converted into inch-pound units. The elongation determined in SI unit gage lengths of 50 or 200 mm may be reported in inch-pound gage lengths of 2 or 8 in., respectively, as applicable.

1.6 Attention is directed to Practice A 880 when there may be a need for information on criteria for evaluation of testing laboratories.

1.7 *This standard does not purport to address all of the safety problems, if any, associated with its use. It is the responsibility of the user of this standard to establish appropriate safety and health practices and determine the applicability of regulatory limitations prior to use.*

2. Referenced Documents

2.1 ASTM Standards:

- A 356/A 356M Specification for Heavy-Walled, Carbon, Low Alloy, and Stainless Steel Castings for Steam Turbines³
- A 416 Specification for Steel Strand, Uncoated Seven-Wire Stress-Relieved for Prestressed Concrete⁴
- A 703/A 703M Specification for Steel Castings, General Requirements, for Pressure-Containing Parts³
- A 781/A 781M Specification for Castings, Steel and Alloy, Common Requirements, for General Industrial Use³
- A 880 Practice for Criteria for Use in Evaluation of Testing Laboratories and Organizations for Examination and Inspection of Steel, Stainless Steel, and Related Alloys⁵
- E 4 Practices for Load Verification of Testing Machines⁶
- E 6 Terminology Relating to Methods of Mechanical Testing⁶
- E 8 Test Methods for Tension Testing of Metallic Materials⁶
- E 8M Test Methods for Tension Testing of Metallic Materials [Metric]⁶
- E 10 Test Method for Brinell Hardness of Metallic Materials⁶
- E 18 Test Methods for Rockwell Hardness and Rockwell Superficial Hardness of Metallic Materials⁶
- E 23 Test Methods for Notched Bar Impact Testing of Metallic Materials⁶
- E 29 Practice for Using Significant Digits in Test Data to Determine Conformance with Specifications⁷

¹ These test methods and definitions are under the jurisdiction of ASTM Committee A-1 on Steel, Stainless Steel and Related Alloys and are the direct responsibility of Subcommittee A01.13 on Methods of Mechanical Testing.

Current edition approved Jan. 15, 1992. Published March 1992. Originally published as A 370 – 53 T. Last previous edition A 370 – 91b.

² For ASME Boiler and Pressure Vessel Code applications see related Specification SA-370 in Section II of that Code.

³ Annual Book of ASTM Standards, Vol 01.02.

⁴ Annual Book of ASTM Standards, Vol 01.04.

⁵ Annual Book of ASTM Standards, Vol 01.03.

⁶ Annual Book of ASTM Standards, Vol 03.01.

⁷ Annual Book of ASTM Standards, Vol 14.02.

- E 83 Practice for Verification and Classification of Extensometers⁶
- E 110 Test Method for Indentation Hardness of Metallic Materials by Portable Hardness Testers⁶
- E 190 Method for Guided Bend Test for Ductility of Welds⁷
- E 208 Test Method for Conducting Drop-Weight Test to Determine Nil-Ductility Transition Temperature of Ferritic Steels⁶
- E 290 Test Method for Semi-Guided Bend Test for Ductility of Metallic Materials⁷
- 2.2 *Other Document:*
ASME Boiler and Pressure Vessel Code, Section VIII, Division I, Part UG-84⁸

3. General Precautions

3.1 Certain methods of fabrication such as bending, forming, and welding, or operations involving heating, may affect the properties of the material under test. Therefore, the product specifications cover the stage of manufacture at which mechanical testing is to be performed. The properties shown by testing prior to fabrication may not necessarily be representative of the product after it has been completely fabricated.

3.2 Improper machining or preparation of test specimens may give erroneous results. Care should be exercised to assure good workmanship in machining. Improperly machined specimens should be discarded and other specimens substituted.

3.3 Flaws in the specimen may also affect results. If any test specimen develops flaws, the retest provision of the applicable product specification shall govern.

3.4 If any test specimen fails because of mechanical reasons such as failure of testing equipment or improper specimen preparation, it may be discarded and another specimen taken.

4. Orientation of Test Specimens

4.1 The terms "longitudinal test" and "transverse test" are used only in material specifications for wrought products and are not applicable to castings. When such reference is made to a test coupon or test specimen, the following definitions apply:

4.1.1 *Longitudinal Test*, unless specifically defined otherwise, signifies that the lengthwise axis of the specimen is parallel to the direction of the greatest extension of the steel during rolling or forging. The stress applied to a longitudinal tension test specimen is in the direction of the greatest extension, and the axis of the fold of a longitudinal bend test specimen is at right angles to the direction of greatest extension (Figs. 1, 2(a), and 2(b)).

4.1.2 *Transverse Test*, unless specifically defined otherwise, signifies that the lengthwise axis of the specimen is at right angles to the direction of the greatest extension of the steel during rolling or forging. The stress applied to a transverse tension test specimen is at right angles to the greatest extension, and the axis of the fold of a transverse

bend test specimen is parallel to the greatest extension (Fig. 1).

4.2 The terms "radial test" and "tangential test" are used in material specifications for some wrought circular products and are not applicable to castings. When such reference is made to a test coupon or test specimen, the following definitions apply:

4.2.1 *Radial Test*, unless specifically defined otherwise, signifies that the lengthwise axis of the specimen is perpendicular to the axis of the product and coincident with one of the radii of a circle drawn with a point on the axis of the product as a center (Fig. 2(a)).

4.2.2 *Tangential Test*, unless specifically defined otherwise, signifies that the lengthwise axis of the specimen is perpendicular to a plane containing the axis of the product and tangent to a circle drawn with a point on the axis of the product as a center (Figs. 2(a), 2(b), 2(c), and 2(d)).

TENSION TEST

5. Description

5.1 The tension test related to the mechanical testing of steel products subjects a machined or full-section specimen of the material under examination to a measured load sufficient to cause rupture. The resulting properties sought are defined in Terminology E 6.

5.2 In general the testing equipment and methods are given in Test Methods E 8. However, there are certain exceptions to Test Methods E 8 practices in the testing of steel, and these are covered in these test methods.

6. Test Specimen Parameters

6.1 *Selection*—Test coupons shall be selected in accordance with the applicable product specifications.

6.1.1 *Wrought Steels*—Wrought steel products are usually tested in the longitudinal direction, but in some cases, where size permits and the service justifies it, testing is in the transverse, radial, or tangential directions (see Figs. 1 and 2).

6.1.2 *Forged Steels*—For open die forgings, the metal for tension testing is usually provided by allowing extensions or prolongations on one or both ends of the forgings, either on all or a representative number as provided by the applicable product specifications. Test specimens are normally taken at mid-radius. Certain product specifications permit the use of a representative bar or the destruction of a production part for test purposes. For ring or disk-like forgings test metal is provided by increasing the diameter, thickness, or length of the forging. Upset disk or ring forgings, which are worked or extended by forging in a direction perpendicular to the axis of the forging, usually have their principal extension along concentric circles and for such forgings tangential tension specimens are obtained from extra metal on the periphery or end of the forging. For some forgings, such as rotors, radial tension tests are required. In such cases the specimens are cut or trepanned from specified locations.

6.1.3 *Cast Steels*—Test coupons for castings from which tension test specimens are prepared shall be in accordance with the requirements of Specifications A 703/A 703M or A 781/A 781M, as applicable.

6.2 *Size and Tolerances*—Test specimens shall be the full thickness or section of material as-rolled, or may be ma-

⁶ Available from American Society of Mechanical Engineers, 345 E. 47th Street, New York, NY 10017.

chined to the form and dimensions shown in Figs. 3 and 6, inclusive. The selection of size and type of specimen is prescribed by the applicable product specification. Full section specimens shall be tested in 8-in. (200-mm) gage length unless otherwise specified in the product specification.

6.3 *Procurement of Test Specimens*—Specimens shall be sheared, blanked, sawed, trepanned, or oxygen-cut from portions of the material. They are usually machined so as to have a reduced cross section at mid-length in order to obtain uniform distribution of the stress over the cross section and to localize the zone of fracture. When test coupons are sheared, blanked, sawed, or oxygen-cut, care shall be taken to remove by machining all distorted, cold-worked, or heat-affected areas from the edges of the section used in evaluating the test.

6.4 *Aging of Test Specimens*—Unless otherwise specified, it shall be permissible to age tension test specimens. The time-temperature cycle employed must be such that the effects of previous processing will not be materially changed. It may be accomplished by aging at room temperature 24 to 48 h, or in shorter time at moderately elevated temperatures boiling in water, heating in oil or in an oven.

6.5 *Measurement of Dimensions of Test Specimens:*

6.5.1 *Standard Rectangular Tension Test Specimens*—These forms of specimens are shown in Fig. 3. To determine the cross-sectional area, the center width dimension shall be measured to the nearest 0.005 in. (0.13 mm) for the 8-in. (200-mm) gage length specimen and 0.001 in. (0.025 mm) for the 2-in. (50-mm) gage length specimen in Fig. 3. The center thickness dimension shall be measured to the nearest 0.001 in. for both specimens.

6.5.2 *Standard Round Tension Test Specimens*—These forms of specimens are shown in Figs. 4 and 5. To determine the cross-sectional area, the diameter shall be measured at the center of the gage length to the nearest 0.001 in. (0.025 mm). (See Table 1.)

6.6 *General*—Test specimens shall be either substantially full size or machined, as prescribed in the product specifications for the material being tested.

6.6.1 Improperly prepared test specimens often cause unsatisfactory test results. It is important, therefore, that care be exercised in the preparation of specimens, particularly in machining, to assure good workmanship.

6.6.2 It is desirable to have the cross-sectional area of the specimen smallest at the center of the gage length to ensure fracture within the gage length. This is provided for by the taper in the gage length permitted for each of the specimens described in the following sections.

6.6.3 For brittle materials it is desirable to have fillets of large radius at the ends of the gage length.

7. Plate-Type Specimen

7.1 The standard plate-type test specimen is shown in Fig. 3. This specimen is used for testing metallic materials in the form of plate, structural and bar-size shapes, and flat material having a nominal thickness of $\frac{3}{16}$ in. (5 mm) or over. When product specifications so permit, other types of specimens may be used.

NOTE 1—When called for in the product specification, the 8-in. gage length specimen of Fig. 3 may be used for sheet and strip material.

8. Sheet-Type Specimen

8.1 The standard sheet-type test specimen is shown in Fig. 3. This specimen is used for testing metallic materials in the form of sheet, plate, flat wire, strip, band, and hoop ranging in nominal thickness from 0.005 to $\frac{3}{4}$ in. (0.13 to 19 mm). When product specifications so permit, other types of specimens may be used, as provided in Section 7.

9. Round Specimens

9.1 The standard 0.500-in. (12.5-mm) diameter round test specimen shown in Fig. 4 is used quite generally for testing metallic materials, both cast and wrought.

9.2 Figure 4 also shows small size specimens proportional to the standard specimen. These may be used when it is necessary to test material from which the standard specimen or specimens shown in Fig. 3 cannot be prepared. Other sizes of small round specimens may be used. In any such small size specimen it is important that the gage length for measurement of elongation be four times the diameter of the specimen (see Note 4, Fig. 4).

9.3 The shape of the ends of the specimens outside of the gage length shall be suitable to the material and of a shape to fit the holders or grips of the testing machine so that the loads are applied axially. Figure 5 shows specimens with various types of ends that have given satisfactory results.

10. Gage Marks

10.1 The specimens shown in Figs. 3, 4, and 6 shall be gage marked with a center punch, scribe marks, multiple device, or drawn with ink. The purpose of these gage marks is to determine the percent elongation. Punch marks shall be light, sharp, and accurately spaced. The localization of stress at the marks makes a hard specimen susceptible to starting fracture at the punch marks. The gage marks for measuring elongation after fracture shall be made on the flat or on the edge of the flat tension test specimen and within the parallel section; for the 8-in. gage length specimen, Fig. 3, one or more sets of 8-in. gage marks may be used, intermediate marks within the gage length being optional. Rectangular 2-in. gage length specimens, Fig. 3, and round specimens, Fig. 4, are gage marked with a double-pointed center punch or scribe marks. In both cases the gage points shall be approximately equidistant from the center of the length of the reduced section. These same precautions shall be observed when the test specimen is full section.

11. Testing Apparatus and Operations

11.1 *Loading Systems*—There are two general types of loading systems, mechanical (screw power) and hydraulic. These differ chiefly in the variability of the rate of load application. The older screw power machines are limited to a small number of fixed free running crosshead speeds. Some modern screw power machines, and all hydraulic machines permit stepless variation throughout the range of speeds.

11.2 The tension testing machine shall be maintained in good operating condition, used only in the proper loading range, and calibrated periodically in accordance with the latest revision of Practices E 4.

NOTE 2—Many machines are equipped with stress-strain recorders for autographic plotting of stress-strain curves. It should be noted that

some recorders have a load measuring component entirely separate from the load indicator of the testing machine. Such recorders are calibrated separately.

11.3 Loading—It is the function of the gripping or holding device of the testing machine to transmit the load from the heads of the machine to the specimen under test. The essential requirement is that the load shall be transmitted axially. This implies that the centers of the action of the grips shall be in alignment, insofar as practicable, with the axis of the specimen at the beginning and during the test, and that bending or twisting be held to a minimum. Gripping of the specimen shall be restricted to the section outside the gage length. In the case of certain sections tested in full size, nonaxial loading is unavoidable and in such cases shall be permissible.

11.4 Speed of Testing—The speed of testing shall not be greater than that at which load and strain readings can be made accurately. In production testing, speed of testing is commonly expressed (1) in terms of free running crosshead speed (rate of movement of the crosshead of the testing machine when not under load), or (2) in terms of rate of separation of the two heads of the testing machine under load, or (3) in terms of rate of stressing the specimen, or (4) in terms of rate of straining the specimen. The following limitations on the speed of testing are recommended as adequate for most steel products:

NOTE 3—Tension tests using closed-loop machines (with feedback control of rate) should not be performed using load control, as this mode of testing will result in acceleration of the crosshead upon yielding and elevation of the measured yield strength.

11.4.1 Any convenient speed of testing may be used up to one half the specified yield point or yield strength. When this point is reached, the free-running rate of separation of the crossheads shall be adjusted so as not to exceed $\frac{1}{16}$ in. per min per inch of reduced section, or the distance between the grips for test specimens not having reduced sections. This speed shall be maintained through the yield point or yield strength. In determining the tensile strength, the free-running rate of separation of the heads shall not exceed $\frac{1}{2}$ in. per min per inch of reduced section, or the distance between the grips for test specimens not having reduced sections. In any event, the minimum speed of testing shall not be less than $\frac{1}{10}$ the specified maximum rates for determining yield point or yield strength and tensile strength.

11.4.2 It shall be permissible to set the speed of the testing machine by adjusting the free running crosshead speed to the above specified values, inasmuch as the rate of separation of heads under load at these machine settings is less than the specified values of free running crosshead speed.

11.4.3 As an alternative, if the machine is equipped with a device to indicate the rate of loading, the speed of the machine from half the specified yield point or yield strength through the yield point or yield strength may be adjusted so that the rate of stressing does not exceed 100,000 psi (690 MPa)/min. However, the minimum rate of stressing shall not be less than 10,000 psi (70 MPa)/min.

12. Terminology

12.1 For definitions of terms pertaining to tension testing, including tensile strength, yield point, yield strength, elongation, and reduction of area, reference should be made to Terminology E 6.

13. Determination of Tensile Properties

13.1 Yield Point—Yield point is the first stress in a material, less than the maximum obtainable stress, at which an increase in strain occurs without an increase in stress. Yield point is intended for application only for materials that may exhibit the unique characteristic of showing an increase in strain without an increase in stress. The stress-strain diagram is characterized by a sharp knee or discontinuity. Determine yield point by one of the following methods:

13.1.1 Drop of the Beam or Halt of the Pointer Method—In this method apply an increasing load to the specimen at a uniform rate. When a lever and poise machine is used, keep the beam in balance by running out the poise at approximately a steady rate. When the yield point of the material is reached, the increase of the load will stop, but run the poise a trifle beyond the balance position, and the beam of the machine will drop for a brief but appreciable interval of time. When a machine equipped with a load-indicating dial is used there is a halt or hesitation of the load-indicating pointer corresponding to the drop of the beam. Note the load at the "drop of the beam" or the "halt of the pointer" and record the corresponding stress as the yield point.

13.1.2 Autographic Diagram Method—When a sharp-kneed stress-strain diagram is obtained by an autographic recording device, take the stress corresponding to the top of the knee (Fig. 7), or the stress at which the curve drops as the yield point (Fig. 7).

13.1.3 Total Extension Under Load Method—When testing material for yield point and the test specimens may not exhibit a well-defined disproportionate deformation that characterizes a yield point as measured by the drop of the beam, halt of the pointer, or autographic diagram methods described in 13.1.1 and 13.1.2, a value equivalent to the yield point in its practical significance may be determined by the following method and may be recorded as yield point: Attach a Class C or better extensometer (Notes 4 and 5) to the specimen. When the load producing a specified extension (Note 6) is reached record the stress corresponding to the load as the yield point, and remove the extensometer (Fig. 8).

NOTE 4—Automatic devices are available that determine the load at the specified total extension without plotting a stress-strain curve. Such devices may be used if their accuracy has been demonstrated. Multiplying calipers and other such devices are acceptable for use provided their accuracy has been demonstrated as equivalent to a Class C extensometer.

NOTE 5—Reference should be made to Practice E 83.

NOTE 6—For steel with a yield point specified not over 80 000 psi (550 MPa), an appropriate value is 0.005 in./in. of gage length. For values above 80 000 psi, this method is not valid unless the limiting total extension is increased.

NOTE 7—The shape of the initial portion of an autographically determined stress-strain (or a load-elongation) curve may be influenced by numerous factors such as the seating of the specimen in the grips, the straightening of a specimen bent due to residual stresses, and the rapid loading permitted in 11.4.1. Generally, the aberrations in this portion of the curve should be ignored when fitting a modulus line, such as that used to determine the offset or extension-under-load yield, to the curve.

13.2 Yield Strength—Yield strength is the stress at which a material exhibits a specified limiting deviation from the proportionality of stress to strain. The deviation is expressed in terms of strain, percent offset, total extension under load, etc. Determine yield strength by one of the following methods:

13.2.1 *Offset Method*—To determine the yield strength by the “offset method,” it is necessary to secure data (autographic or numerical) from which a stress-strain diagram may be drawn. Then on the stress-strain diagram (Fig. 9) lay off Om equal to the specified value of the offset, draw mn parallel to OA , and thus locate r , the intersection of mn with the stress-strain curve corresponding to load R which is the yield strength load. In recording values of yield strength obtained by this method, the specified value of “off-set” used shall be stated in parentheses after the term yield strength, thus:

$$\text{Yield strength (0.2 \% offset)} = 52\,000 \text{ psi (360 MPa)}$$

In using this method, a minimum extensometer magnification of 250 to 1 is required. A Class B1 extensometer meets this requirement (see Note 5). See also Note 8 for automatic devices.

13.2.2 *Extension Under Load Method*—For tests to determine the acceptance or rejection of material whose stress-strain characteristics are well known from previous tests of similar material in which stress-strain diagrams were plotted, the total strain corresponding to the stress at which the specified offset (see Notes 8 and 9) occurs will be known within satisfactory limits. The stress on the specimen, when this total strain is reached, is the value of the yield strength. The total strain can be obtained satisfactorily by use of a Class B1 extensometer (Notes 4 and 5).

NOTE 8—Automatic devices are available that determine offset yield strength without plotting a stress-strain curve. Such devices may be used if their accuracy has been demonstrated.

NOTE 9—The appropriate magnitude of the extension under load will obviously vary with the strength range of the particular steel under test. In general, the value of extension under load applicable to steel at any strength level may be determined from the sum of the proportional strain and the plastic strain expected at the specified yield strength. The following equation is used:

$$\text{Extension under load, in./in. of gage length} = (YS/E) + r$$

where:

- YS = specified yield strength, psi or MPa,
- E = modulus of elasticity, psi or MPa, and
- r = limiting plastic strain, in./in.

NOTE 10—The shape of the initial portion of an autographically determined stress-strain (or a load-elongation) curve may be influenced by numerous factors such as the seating of the specimen in the grips, the straightening of a specimen bent due to residual stresses, and the rapid loading permitted in 11.4.1. Generally, the aberrations in this portion of the curve should be ignored when fitting a modulus line, such as that used to determine the offset or extension-under-load yield, to the curve.

13.3 *Tensile Strength*—Calculate the tensile strength by dividing the maximum load the specimen sustains during a tension test by the original cross-sectional area of the specimen.

13.4 *Elongation:*

13.4.1 Fit the ends of the fractured specimen together carefully and measure the distance between the gage marks to the nearest 0.01 in. (0.25 mm) for gage lengths of 2 in. and under, and to the nearest 0.5 % of the gage length for gage lengths over 2 in. A percentage scale reading to 0.5 % of the gage length may be used. The elongation is the increase in length of the gage length, expressed as a percentage of the original gage length. In recording elongation values, give both the percentage increase and the original gage length.

13.4.2 If any part of the fracture takes place outside of the

middle half of the gage length or in a punched or scribed mark within the reduced section, the elongation value obtained may not be representative of the material. If the elongation so measured meets the minimum requirements specified, no further testing is indicated, but if the elongation is less than the minimum requirements, discard the test and retest.

13.5 *Reduction of Area*—Fit the ends of the fractured specimen together and measure the mean diameter or the width and thickness at the smallest cross section to the same accuracy as the original dimensions. The difference between the area thus found and the area of the original cross section expressed as a percentage of the original area, is the reduction of area.

BEND TEST

14. Description

14.1 The bend test is one method for evaluating ductility, but it cannot be considered as a quantitative means of predicting service performance in bending operations. The severity of the bend test is primarily a function of the angle of bend and inside diameter to which the specimen is bent, and of the cross section of the specimen. These conditions are varied according to location and orientation of the test specimen and the chemical composition, tensile properties, hardness, type, and quality of the steel specified. Method E 190 and Test Method E 290 may be consulted for methods of performing the test.

14.2 Unless otherwise specified, it shall be permissible to age bend test specimens. The time-temperature cycle employed must be such that the effects of previous processing will not be materially changed. It may be accomplished by aging at room temperature 24 to 48 h, or in shorter time at moderately elevated temperatures by boiling in water, heating in oil, or in an oven.

14.3 Bend the test specimen at room temperature to an inside diameter, as designated by the applicable product specifications, to the extent specified without major cracking on the outside of the bent portion. The speed of bending is ordinarily not an important factor.

HARDNESS TEST

15. General

15.1 A hardness test is a means of determining resistance to penetration and is occasionally employed to obtain a quick approximation of tensile strength. Tables 2A, 2B, 2C, and 2D are for the conversion of hardness measurements from one scale to another or to approximate tensile strength. These conversion values have been obtained from computer-generated curves and are presented to the nearest 0.1 point to permit accurate reproduction of those curves. Since all converted hardness values must be considered approximate, however, all converted Rockwell hardness numbers shall be rounded to the nearest whole number.

16. Brinell Test

16.1 *Description:*

16.1.1 A specified load is applied to a flat surface of the specimen to be tested, through a hard ball of specified diameter. The average diameter of the indentation is used as

a basis for calculation of the Brinell hardness number. The quotient of the applied load divided by the area of the surface of the indentation, which is assumed to be spherical, is termed the Brinell hardness number (HB) in accordance with the following equation:

$$HB = P / [(\pi D/2)(D - \sqrt{D^2 - d^2})]$$

where:

- HB = Brinell hardness number,
- P = applied load, kgf,
- D = diameter of the steel ball, mm, and
- d = average diameter of the indentation, mm.

NOTE 11—The Brinell hardness number is more conveniently secured from standard tables such as Table 3 which show numbers corresponding to the various indentation diameters, usually in increments of 0.05 mm.

NOTE 12—In Test Method E 10, the values are stated in SI units whereas in this section, kg/m units are used.

16.1.2 The standard Brinell test using a 10-mm ball employs a 3000-kgf load for hard materials and a 1500 or 500-kgf load for thin sections or soft materials (see Annex A2 on Steel Tubular Products). Other loads and different size indentors may be used when specified. In recording hardness values, the diameter of the ball and the load must be stated except when a 10-mm ball and 3000-kgf load are used.

16.1.3 A range of hardness can properly be specified only for quenched and tempered or normalized and tempered material. For annealed material a maximum figure only should be specified. For normalized material a minimum or a maximum hardness may be specified by agreement. In general, no hardness requirements should be applied to untreated material.

16.1.4 Brinell hardness may be required when tensile properties are not specified.

16.2 Apparatus—Equipment shall meet the following requirements:

16.2.1 Testing Machine—A Brinell hardness testing machine is acceptable for use over a loading range within which its load measuring device is accurate to $\pm 1\%$.

16.2.2 Measuring Microscope—The divisions of the micrometer scale of the microscope or other measuring devices used for the measurement of the diameter of the indentations shall be such as to permit the direct measurement of the diameter to 0.1 mm and the estimation of the diameter to 0.05 mm.

NOTE 13—This requirement applies to the construction of the microscope only and is not a requirement for measurement of the indentation, see 16.4.3.

16.2.3 Standard Ball—The standard ball for Brinell hardness testing is 10 mm (0.3937 in.) in diameter with a deviation from this value of not more than 0.005 mm (0.0004 in.) in any diameter. A ball suitable for use must not show a permanent change in diameter greater than 0.01 mm (0.0004 in.) when pressed with a force of 3000 kgf against the test specimen.

16.3 Test Specimen—Brinell hardness tests are made on prepared areas and sufficient metal must be removed from the surface to eliminate decarburized metal and other surface irregularities. The thickness of the piece tested must be such that no bulge or other marking showing the effect of the load

appears on the side of the piece opposite the indentation.

16.4 Procedure:

16.4.1 It is essential that the applicable product specifications state clearly the position at which Brinell hardness indentations are to be made and the number of such indentations required. The distance of the center of the indentation from the edge of the specimen or edge of another indentation must be at least two and one-half times the diameter of the indentation.

16.4.2 Apply the load for a minimum of 15 s.

16.4.3 Measure two diameters of the indentation at right angles to the nearest 0.1 mm, estimate to the nearest 0.05 mm, and average to the nearest 0.05 mm. If the two diameters differ by more than 0.1 mm, discard the readings and make a new indentation.

16.4.4 Do not use a steel ball on steels having a hardness over 450 HB nor a carbide ball over 650 HB. The Brinell test is not recommended for materials having a HB over 650.

16.5 Detailed Procedure—For detailed requirements of this test, reference shall be made to the latest revision of Test Method E 10.

17. Portable Hardness Test

17.1 Portable Testers—Under certain circumstances, it may be desirable to substitute a portable Brinell testing instrument, which is calibrated to give equivalent results to those of a standard Brinell machine on a comparison test bar of approximately the same hardness as the material to be tested.

17.2 Detailed Procedure—For detailed requirements of the portable test, reference shall be made to the latest revision of Test Method E 110.

18. Rockwell Test

18.1 Description:

18.1.1 In this test a hardness value is obtained by determining the depth of penetration of a diamond point or a steel ball into the specimen under certain arbitrarily fixed conditions. A minor load of 10 kgf is first applied which causes an initial penetration, sets the penetrator on the material and holds it in position. A major load which depends on the scale being used is applied increasing the depth of indentation. The major load is removed and, with the minor load still acting, the Rockwell number, which is proportional to the difference in penetration between the major and minor loads is determined; this is usually done by the machine and shows on a dial, digital display, printer, or other device. This is an arbitrary number which increases with increasing hardness. The scales most frequently used are as follows:

Scale Symbol	Penetrator	Major Load, kgf	Minor Load, kgf
B	1/16-in. steel ball	100	10
C	Diamond brale	150	10

18.1.2 Rockwell superficial hardness machines are used for the testing of very thin steel or thin surface layers. Loads of 15, 30, or 45 kgf are applied on a hardened steel ball or diamond penetrator, to cover the same range of hardness values as for the heavier loads. The superficial hardness scales are as follows:

Scale Symbol	Penetrator	Major Load, kgf	Minor Load, kgf
15T	1/16-in. steel ball	15	3
30T	1/16-in. steel ball	30	3
45T	1/16-in. steel ball	45	3
15N	Diamond brale	15	3
30N	Diamond brale	30	3
45N	Diamond brale	45	3

18.2 *Reporting Hardness*—In recording hardness values, the hardness number shall always precede the scale symbol, for example: 96 HRB, 40 HRC, 75 HR15N, or 77 HR30T.

18.3 *Test Blocks*—Machines should be checked to make certain they are in good order by means of standardized Rockwell test blocks.

18.4 *Detailed Procedure*—For detailed requirements of this test, reference shall be made to the latest revision of Test Methods E 18.

CHARPY IMPACT TESTING

19. Summary

19.1 A Charpy V-notch impact test is a dynamic test in which a notched specimen is struck and broken by a single blow in a specially designed testing machine. The measured test values may be the energy absorbed, the percentage shear fracture, the lateral expansion opposite the notch, or a combination thereof.

19.2 Testing temperatures other than room (ambient) temperature often are specified in product or general requirement specifications (hereinafter referred to as the specification). Although the testing temperature is sometimes related to the expected service temperature, the two temperatures need not be identical.

20. Significance and Use

20.1 *Ductile vs. Brittle Behavior*—Body-centered-cubic or ferritic alloys exhibit a significant transition in behavior when impact tested over a range of temperatures. At temperatures above transition, impact specimens fracture by a ductile (usually microvoid coalescence) mechanism, absorbing relatively large amounts of energy. At lower temperatures, they fracture in a brittle (usually cleavage) manner absorbing less energy. Within the transition range, the fracture will generally be a mixture of areas of ductile fracture and brittle fracture.

20.2 The temperature range of the transition from one type of behavior to the other varies according to the material being tested. This transition behavior may be defined in various ways for specification purposes.

20.2.1 The specification may require a minimum test result for absorbed energy, fracture appearance, lateral expansion, or a combination thereof, at a specified test temperature.

20.2.2 The specification may require the determination of the transition temperature at which either the absorbed energy or fracture appearance attains a specified level when testing is performed over a range of temperatures.

20.3 Further information on the significance of impact testing appears in Annex A5.

21. Apparatus

21.1 *Testing Machines:*

21.1.1 A Charpy impact machine is one in which a notched specimen is broken by a single blow of a freely swinging pendulum. The pendulum is released from a fixed height. Since the height to which the pendulum is raised prior to its swing, and the mass of the pendulum are known, the energy of the blow is predetermined. A means is provided to indicate the energy absorbed in breaking the specimen.

21.1.2 The other principal feature of the machine is a fixture (See Fig. 10) designed to support a test specimen as a simple beam at a precise location. The fixture is arranged so that the notched face of the specimen is vertical. The pendulum strikes the other vertical face directly opposite the notch. The dimensions of the specimen supports and striking edge shall conform to Fig. 10.

21.1.3 Charpy machines used for testing steel generally have capacities in the 220 to 300 ft·lbf (300 to 400 J) energy range. Sometimes machines of lesser capacity are used; however, the capacity of the machine should be substantially in excess of the absorbed energy of the specimens (see Test Methods E 23). The linear velocity at the point of impact should be in the range of 16 to 19 ft/s (4.9 to 5.8 m/s).

21.2 *Temperature Media:*

21.2.1 For testing at other than room temperature, it is necessary to condition the Charpy specimens in media at controlled temperatures.

21.2.2 Low temperature media usually are chilled fluids (such as water, ice plus water, dry ice plus organic solvents, or liquid nitrogen) or chilled gases.

21.2.3 Elevated temperature media are usually heated liquids such as mineral or silicone oils. Circulating air ovens may be used.

21.3 *Handling Equipment*—Tongs, especially adapted to fit the notch in the impact specimen, normally are used for removing the specimens from the medium and placing them on the anvil (refer to Test Methods E 23). In cases where the machine fixture does not provide for automatic centering of the test specimen, the tongs may be precision machined to provide centering.

22. Sampling and Number of Specimens

22.1 *Sampling:*

22.1.1 Test location and orientation should be addressed by the specifications. If not, for wrought products, the test location shall be the same as that for the tensile specimen and the orientation shall be longitudinal with the notch perpendicular to the major surface of the product being tested.

22.1.2 *Number of Specimens.*

22.1.2.1 A Charpy impact test consists of all specimens taken from a single test coupon or test location.

22.1.2.2 When the specification calls for a minimum average test result, three specimens shall be tested.

22.1.2.3 When the specification requires determination of a transition temperature, eight to twelve specimens are usually needed.

22.2 *Type and Size:*

22.2.1 Use a standard size Charpy V-notch specimen (Type A) as shown in Fig. 11, except as allowed in 22.2.2.

22.2.2 *Subsized Specimens.*

22.2.2.1 For flat material less than 7/16 in. (11 mm) thick, or when the absorbed energy is expected to exceed 80 % of

full scale, use subsize test specimens.

22.2.2.2 For tubular materials tested in the transverse direction, where the relationship between diameter and wall thickness does not permit a standard size specimen, use subsize test specimens.

22.2.2.3 If a full-size specimen cannot be prepared, the largest feasible standard subsize specimen shall be prepared. The specimens shall be machined so that the specimen does not include material nearer to the surface than 0.020 in. (0.5 mm).

22.2.2.4 Tolerances for subsize specimens are shown in Fig. 11. Standard subsize test specimen sizes are: 10 × 7.5 mm, 10 × 6.7 mm, 10 × 5 mm, 10 × 3.3 mm, and 10 × 2.5 mm.

22.2.2.5 Notch the narrow face of the specimens so that the notch is perpendicular to the 10 mm wide face.

22.3 *Notch Preparation*—The machining of the notch is critical, as it has been demonstrated that extremely minor variations in notch radius and profile, or tool marks at the bottom of the notch may result in erratic test data. (See Annex A5).

23. Calibration

23.1 *Accuracy and Sensitivity*—Calibrate and adjust Charpy impact machines in accordance with the requirements of Test Methods E 23.

24. Conditioning—Temperature Control

24.1 When a specific test temperature is required by the specification or purchaser, control the temperature of the heating or cooling medium within $\pm 2^{\circ}\text{F}$ (1°C) because the effect of variations in temperature on Charpy test results can be very great.

NOTE 14—For some steels there may not be a need for this restricted temperature, for example, austenitic steels.

NOTE 15—Because the temperature of a testing laboratory often varies from 60 to 90°F (15 to 32°C) a test conducted at “room temperature” might be conducted at any temperature in this range.

25. Procedure

25.1 *Temperature:*

25.1.1 Condition the specimens to be broken by holding them in the medium at test temperature for at least 5 min in liquid media and 30 min in gaseous media.

25.1.2 Prior to each test, maintain the tongs for handling test specimens at the same temperature as the specimen so as not to affect the temperature at the notch.

25.2 *Positioning and Breaking Specimens:*

25.2.1 Carefully center the test specimen in the anvil and release the pendulum to break the specimen.

25.2.2 If the pendulum is not released within 5 s after removing the specimen from the conditioning medium, do not break the specimen. Return the specimen to the conditioning medium for the period required in 25.1.1.

25.3 *Recovering Specimens*—In the event that fracture appearance or lateral expansion must be determined, recover the matched pieces of each broken specimen before breaking the next specimen.

25.4 *Individual Test Values:*

25.4.1 *Impact energy*—Record the impact energy absorbed to the nearest ft·lbf (J).

25.4.2 *Fracture Appearance:*

25.4.2.1 Determine the percentage of shear fracture area by any of the following methods:

(1) Measure the length and width of the brittle portion of the fracture surface, as shown in Fig. 12 and determine the percent shear area from either Table 4 or 5 depending on the units of measurement.

(2) Compare the appearance of the fracture of the specimen with a fracture appearance chart as shown in Fig. 13.

(3) Magnify the fracture surface and compare it to a precalibrated overlay chart or measure the percent shear fracture area by means of a planimeter.

(4) Photograph the fractured surface at a suitable magnification and measure the percent shear fracture area by means of a planimeter.

25.4.2.2 Determine the individual fracture appearance values to the nearest 5 % shear fracture and record the value.

25.4.3 *Lateral Expansion:*

25.4.3.1 Lateral expansion is the increase in specimen width, measured in thousandths of an inch (mils), on the compression side, opposite the notch of the fractured Charpy V-notch specimen as shown in Fig. 14.

25.4.3.2 Examine each specimen half to ascertain that the protrusions have not been damaged by contacting the anvil, machine mounting surface, and so forth. Discard such samples since they may cause erroneous readings.

25.4.3.3 Check the sides of the specimens perpendicular to the notch to ensure that no burrs were formed on the sides during impact testing. If burrs exist, remove them carefully by rubbing on emery cloth or similar abrasive surface, making sure that the protrusions being measured are not rubbed during the removal of the burr.

25.4.3.4 Measure the amount of expansion on each side of each half relative to the plane defined by the undeformed portion of the side of the specimen using a gage similar to that shown in Figs. 15 and 16.

25.4.3.5 Since the fracture path seldom bisects the point of maximum expansion on both sides of a specimen, the sum of the larger values measured for each side is the value of the test. Arrange the halves of one specimen so that compression sides are facing each other. Using the gage, measure the protrusion on each half specimen, ensuring that the same side of the specimen is measured. Measure the two broken halves individually. Repeat the procedure to measure the protrusions on the opposite side of the specimen halves. The larger of the two values for each side is the expansion of that side of the specimen.

25.4.3.6 Measure the individual lateral expansion values to the nearest mil (0.025 mm) and record the values.

26. Interpretation of Test Result

26.1 When the acceptance criterion of any impact test is specified to be a minimum average value at a given temperature, the test result shall be the average (arithmetic mean) of the individual test values of three specimens from one test location.

26.1.1 When a minimum average test result is specified:

26.1.1.1 The test result is acceptable when all of the below are met:

(1) The test result equals or exceeds the specified minimum average (given in the specification),

(2) The individual test value for not more than one specimen measures less than the specified minimum average, and

(3) The individual test value for any specimen measures not less than two-thirds of the specified minimum average.

26.1.1.2 If the acceptance requirements of 26.1.1.1 are not met, perform one retest of three additional specimens from the same test location. Each individual test value of the retested specimens shall be equal to or greater than the specified minimum average value.

26.2 *Test Specifying a Minimum Transition Temperature:*

26.2.1 *Definition of Transition Temperature*—For specification purposes, the transition temperature is the temperature at which the designated material test value equals or exceeds a specified minimum test value.

26.2.2 *Determination of Transition Temperature:*

26.2.2.1 Break one specimen at each of a series of temperatures above and below the anticipated transition temperature using the procedures in Section 25. Record each test temperature to the nearest 1°F (0.5°C).

26.2.2.2 Plot the individual test results (ft·lbf or percent shear) as the ordinate versus the corresponding test temperature as the abscissa and construct a best-fit curve through the plotted data points.

26.2.2.3 If transition temperature is specified as the temperature at which a test value is achieved, determine the temperature at which the plotted curve intersects the specified test value by graphical interpolation (extrapolation is not permitted). Record this transition temperature to the nearest 5°F (3°C). If the tabulated test results clearly indicate a transition temperature lower than specified, it is not necessary to plot the data. Report the lowest test temperature for which test value exceeds the specified value.

26.2.2.4 Accept the test result if the determined transition temperature is equal to or lower than the specified value.

26.2.2.5 If the determined transition temperature is higher than the specified value, but not more than 20°F (12°C) higher than the specified value, test sufficient samples in accordance with Section 25 to plot two additional curves. Accept the test results if the temperatures determined from both additional tests are equal to or lower than the specified value.

26.3 When subsize specimens are permitted or necessary, or both, modify the specified test requirement according to Table 6 or test temperature according to ASME Boiler and Pressure Vessel Code, Table UG-84.2, or both. Greater energies or lower test temperatures may be agreed upon by purchaser and supplier.

27. Records

27.1 The test record should contain the following information as appropriate:

27.1.1 Full description of material tested (that is, specification number, grade, class or type, size, heat number).

27.1.2 Specimen orientation with respect to the material axis.

27.1.3 Specimen size.

27.1.4 Test temperature and individual test value for each specimen broken, including initial tests and retests.

27.1.5 Test results.

27.1.6 Transition temperature and criterion for its determination, including initial tests and retests.

28. Report

28.1 The specification should designate the information to be reported.

ANNEXES

(Mandatory Information)

A1. STEEL BAR PRODUCTS

A1.1 Scope

A1.1.1 This supplement delineates only those details which are peculiar to hot-rolled and cold-finished steel bars and are not covered in the general section of these test methods.

A1.2 Orientation of Test Specimens

A1.2.1 Carbon and alloy steel bars and bar-size shapes, due to their relatively small cross-sectional dimensions, are customarily tested in the longitudinal direction. In special cases where size permits and the fabrication or service of a part justifies testing in a transverse direction, the selection and location of test or tests are a matter of agreement between the manufacturer and the purchaser.

A1.3 Tension Test

A1.3.1 *Carbon Steel Bars*—Carbon steel bars are not

commonly specified to tensile requirements in the as-rolled condition for sizes of rounds, squares, hexagons, and octagons under ½ in. (13 mm) in diameter or distance between parallel faces nor for other bar-size sections, other than flats, less than 1 in.² (645 mm²) in cross-sectional area.

A1.3.2 *Alloy Steel Bars*—Alloy steel bars are usually not tested in the as-rolled condition.

A1.3.3 When tension tests are specified, the practice for selecting test specimens for hot-rolled and cold-finished steel bars of various sizes shall be in accordance with Table A1.1, unless otherwise specified in the product specification.

A1.4 Bend Test

A1.4.1 When bend tests are specified, the recommended practice for hot-rolled and cold-finished steel bars shall be in accordance with Table A1.2.

A1.5 Hardness Test

A1.5.1 *Hardness Tests on Bar Products*—flats, rounds,

squares, hexagons and octagons—is conducted on the surface after a minimum removal of 0.015 in. to provide for accurate hardness penetration.

A2. STEEL TUBULAR PRODUCTS

A2.1 Scope

A2.1.1 This supplement covers definitions and methods of testing peculiar to tubular products which are not covered in the general section of these methods.

A2.1.2 Tubular shapes covered by this specification shall not be limited to products with circular cross sections but include shapes such as rectangular structural tubing.

A2.2 Tension Test

A2.2.1 *Full-Size Longitudinal Test Specimens:*

A2.2.1.1 It is standard practice to use tension test specimens of full-size tubular sections within the limit of the testing equipment. Snug-fitting metal plugs should be inserted far enough in the end of such tubular specimens to permit the testing machine jaws to grip the specimens properly without crushing. A design that may be used for such plugs is shown in Fig. 17. The plugs shall not extend into that part of the specimen on which the elongation is measured (Fig. 17). Care should be exercised to see that insofar as practicable, the load in such cases is applied axially. The length of the full-section specimen depends on the gage length prescribed for measuring the elongation.

A2.2.1.2 Unless otherwise required by the individual product specification, the gage length for furnace-welded pipe is normally 8 in. (200 mm), except that for nominal sizes 3/4 in. and smaller, the gage length shall be as follows:

Nominal Size, in.	Gage Length, in. (mm)
1/4 and 1/2	6 (150)
3/8 and 1/2	4 (100)
1/2	2 (50)

A2.2.1.3 For seamless and electric-welded pipe and tubes the gage length is 2 in. However, for tubing having an outside diameter of 3/8 in. (10 mm) or less, it is customary to use a gage length equal to four times the outside diameter when elongation values comparable to larger specimens are required.

A2.2.1.4 To determine the cross-sectional area of the full-section specimen, measurements shall be recorded as the average or mean between the greatest and least measurements of the outside diameter and the average or mean wall thickness, to the nearest 0.001 in. (0.025 mm) and the cross-sectional area is determined by the following equation:

$$A = 3.1416t(D - t)$$

where:

- A = sectional area, in.²
- D = outside diameter, in., and
- t = thickness of tube wall, in.

NOTE 16—There exist other methods of cross-sectional area determination, such as by weighing of the specimens, which are equally accurate or appropriate for the purpose.

A2.2.2 *Longitudinal Strip Test Specimens:*

A2.2.2.1 For larger sizes of tubular products which cannot

be tested in full-section, longitudinal test specimens are obtained from strips cut from the tube or pipe as indicated in Fig. 18 and machined to the dimensions shown in Fig. 19. For furnace-welded tubes or pipe the 8-in. gage length specimen as shown in Fig. 19 is standard, the specimen being located at approximately 90° from the weld. For seamless and electric-welded tubes or pipe, the 2-in. gage length specimen as shown in Fig. 19 (1) is standard, the specimen being located approximately 90° from the weld in the case of electric-welded tubes. Specimens of the type shown in Fig. 19 may be tested with grips having a surface contour corresponding to the curvature of the tubes. When grips with curved faces are not available, the ends of the specimens may be flattened without heating. Standard tension test specimens, as shown in specimen No. 4 of Fig. 19, are nominally 1 1/2 in. (38 mm) wide in the gage length section. When sub-size specimens are necessary due to the dimensions and character of the material to be tested, specimens 1, 2, or 3 shown in Fig. 19 where applicable, are considered standard.

NOTE 17—An exact formula for calculating the cross-sectional area of specimens of the type shown in Fig. 19 taken from a circular tube is given in Test Methods E8 or E8M.

A2.2.2.2 The width should be measured at each end of the gage length to determine parallelism and also at the center. The thickness should be measured at the center and used with the center measurement of the width to determine the cross-sectional area. The center width dimension should be recorded to the nearest 0.005 in. (0.127 mm), and the thickness measurement to the nearest 0.001 in.

A2.2.3 *Transverse Strip Test Specimens:*

A2.2.3.1 In general, transverse tension tests are not recommended for tubular products, in sizes smaller than 8 in. in nominal diameter. When required, transverse tension test specimens may be taken from rings cut from ends of tubes or pipe as shown in Fig. 20. Flattening of the specimen may be done either after separating it from the tube as in Fig. 20 (a), or before separating it as in Fig. 20 (b), and may be done hot or cold; but if the flattening is done cold, the specimen may subsequently be normalized. Specimens from tubes or pipe for which heat treatment is specified, after being flattened either hot or cold, shall be given the same treatment as the tubes or pipe. For tubes or pipe having a wall thickness of less than 3/4 in. (19 mm), the transverse test specimen shall be of the form and dimensions shown in Fig. 21 and either or both surfaces may be machined to secure uniform thickness. Specimens for transverse tension tests on welded steel tubes or pipe to determine strength of welds, shall be located perpendicular to the welded seams with the weld at about the middle of their length.

A2.2.3.2 The width should be measured at each end of the gage length to determine parallelism and also at the center. The thickness should be measured at the center and used with the center measurement of the width to determine the cross-sectional area. The center width dimension should be

recorded to the nearest 0.005 in. (0.127 mm), and the thickness measurement to the nearest 0.001 in. (0.025 mm).

A2.2.4 Round Test Specimens:

A2.2.4.1 When provided for in the product specification, the round test specimen shown in Fig. 4 may be used.

A2.2.4.2 The diameter of the round test specimen is measured at the center of the specimen to the nearest 0.001 in. (0.025 mm).

A2.2.4.3 Small-size specimens proportional to standard, as shown in Fig. 4, may be used when it is necessary to test material from which the standard specimen cannot be prepared. Other sizes of small-size specimens may be used. In any such small-size specimen, it is important that the gage length for measurement of elongation be four times the diameter of the specimen (see Note 4, Fig. 4). The elongation requirements for the round specimen 2-in. gage length in the product specification shall apply to the small-size specimens.

A2.2.4.4 For transverse specimens, the section from which the specimen is taken shall not be flattened or otherwise deformed.

A.3 Determination of Transverse Yield Strength, Hydraulic Ring-Expansion Method

A2.3.1 Hardness tests are made on the outside surface, inside surface, or wall cross-section depending upon product-specification limitation. Surface preparation may be necessary to obtain accurate hardness values.

A2.3.2 A testing machine and method for determining the transverse yield strength from an annular ring specimen, have been developed and described in A2.3.3 through A2.3.5.

A2.3.3 A diagrammatic vertical cross-sectional sketch of the testing machine is shown in Fig. 22.

A2.3.4 In determining the transverse yield strength on this machine, a short ring (commonly 3 in. (76 mm) in length) test specimen is used. After the large circular nut is removed from the machine, the wall thickness of the ring specimen is determined and the specimen is telescoped over the oil resistant rubber gasket. The nut is then replaced, but is not turned down tight against the specimen. A slight clearance is left between the nut and specimen for the purpose of

permitting free radial movement of the specimen as it is being tested. Oil under pressure is then admitted to the interior of the rubber gasket through the pressure line under the control of a suitable valve. An accurately calibrated pressure gage serves to measure oil pressure. Any air in the system is removed through the bleeder line. As the oil pressure is increased, the rubber gasket expands which in turn stresses the specimen circumferentially. As the pressure builds up, the lips of the rubber gasket act as a seal to prevent oil leakage. With continued increase in pressure, the ring specimen is subjected to a tension stress and elongates accordingly. The entire outside circumference of the ring specimen is considered as the gage length and the strain is measured with a suitable extensometer which will be described later. When the desired total strain or extension under load is reached on the extensometer, the oil pressure in pounds per square inch is read and by employing Barlow's formula, the unit yield strength is calculated. The yield strength, thus determined, is a true result since the test specimen has not been cold worked by flattening and closely

approximates the same condition as the tubular section from which it is cut. Further, the test closely simulates service conditions in pipe lines. One testing machine unit may be used for several different sizes of pipe by the use of suitable rubber gaskets and adapters.

NOTE 18—Barlow's formula may be stated two ways:

$$(1) P = 2St/D$$

$$(2) S = PD/2t$$

where:

P = internal hydrostatic pressure, psi,

S = unit circumferential stress in the wall of the tube produced by the internal hydrostatic pressure, psi,

t = thickness of the tube wall, in., and

D = outside diameter of the tube, in.

A2.3.5 A roller chain type extensometer which has been found satisfactory for measuring the elongation of the ring specimen is shown in Figs. 23 and 24. Figure 23 shows the extensometer in position, but unclamped, on a ring specimen. A small pin, through which the strain is transmitted to and measured by the dial gage, extends through the hollow threaded stud. When the extensometer is clamped, as shown in Fig. 24, the desired tension which is necessary to hold the instrument in place and to remove any slack, is exerted on the roller chain by the spring. Tension on the spring may be regulated as desired by the knurled thumb screw. By removing or adding rollers, the roller chain may be adapted for different sizes of tubular sections.

A2.4 Hardness Tests

A2.4.1 Hardness tests are made either on the outside or the inside surfaces on the end of the tube as appropriate.

A2.4.2 The standard 3000-kgf Brinell load may cause too much deformation in a thin-walled tubular specimen. In this case the 500-kgf load shall be applied, or inside stiffening by means of an internal anvil should be used. Brinell testing shall not be applicable to tubular products less than 2 in. (51 mm) in outside diameter, or less than 0.200 in. (5.1 mm) in wall thickness.

A2.4.3 The Rockwell hardness tests are normally made on the inside surface, a flat on the outside surface, or on the wall cross-section depending upon the product limitation. Rockwell hardness tests are not performed on tubes smaller than 5/16 in. (7.9 mm) in outside diameter, nor are they performed on the inside surface of tubes with less than 1/4 in. (6.4 mm) inside diameter. Rockwell hardness tests are not performed on annealed tubes with walls less than 0.065 in. (1.65 mm) thick or cold worked or heat treated tubes with walls less than 0.049 in. (1.24 mm) thick. For tubes with wall thicknesses less than those permitting the regular Rockwell hardness test, the Superficial Rockwell test is sometimes substituted. Transverse Rockwell hardness readings can be made on tubes with a wall thickness of 0.187 in. (4.75 mm) or greater. The curvature and the wall thickness of the specimen impose limitations on the Rockwell hardness test. When a comparison is made between Rockwell determinations made on the outside surface and determinations made on the inside surface, adjustment of the readings will be required to compensate for the effect of curvature. The Rockwell B scale is used on all materials having an expected hardness range of B 0 to B 100. The Rockwell C scale is used on material

having an expected hardness range of C 20 to C 68.

A2.4.4 Superficial Rockwell hardness tests are normally performed on the outside surface whenever possible and whenever excessive spring back is not encountered. Otherwise, the tests may be performed on the inside. Superficial Rockwell hardness tests shall not be performed on tubes with an inside diameter of less than 1/4 in. (6.4 mm). The wall thickness limitations for the Superficial Rockwell hardness test are given in Tables A2.1 and A2.2.

A2.4.5 When the outside diameter, inside diameter, or wall thickness precludes the obtaining of accurate hardness values, tubular products shall be specified to tensile properties and so tested.

A2.5 Manipulating Tests

A2.5.1 The following tests are made to prove ductility of certain tubular products:

A2.5.1.1 *Flattening Test*—The flattening test as commonly made on specimens cut from tubular products is conducted by subjecting rings from the tube or pipe to a prescribed degree of flattening between parallel plates (Fig. 20). The severity of the flattening test is measured by the distance between the parallel plates and is varied according to the dimensions of the tube or pipe. The flattening test specimen should not be less than 2 1/2 in. (63.5 mm) in length and should be flattened cold to the extent required by the applicable material specifications.

A2.5.1.2 *Reverse Flattening Test*—The reverse flattening test is designed primarily for application to electric-welded tubing for the detection of lack of penetration or overlaps resulting from flash removal in the weld. The specimen consists of a length of tubing approximately 4 in. (102 mm) long which is split longitudinally 90° on each side of the weld. The sample is then opened and flattened with the weld at the point of maximum bend (Fig. 25).

A2.5.1.3 *Crush Test*—The crush test, sometimes referred to as an upsetting test, is usually made on boiler and other pressure tubes, for evaluating ductility (Fig. 26). The specimen is a ring cut from the tube, usually about 2 1/2 in. (63.5 mm) long. It is placed on end and crushed endwise by hammer or press to the distance prescribed by the applicable material specifications.

A2.5.1.4 *Flange Test*—The flange test is intended to

determine the ductility of boiler tubes and their ability to withstand the operation of bending into a tube sheet. The test is made on a ring cut from a tube, usually not less than 4 in. (100 mm) long and consists of having a flange turned over at right angles to the body of the tube to the width required by the applicable material specifications. The flaring tool and die block shown in Fig. 27 are recommended for use in making this test.

A2.5.1.5 *Flaring Test*—For certain types of pressure tubes, an alternate to the flange test is made. This test consists of driving a tapered mandrel having a slope of 1 in 10 as shown in Fig. 28 (a) or a 60° included angle as shown in Fig. 28 (b) into a section cut from the tube, approximately 4 in. (100 mm) in length, and thus expanding the specimen until the inside diameter has been increased to the extent required by the applicable material specifications.

A2.5.1.6 *Bend Test*—For pipe used for coiling in sizes 2 in. and under a bend test is made to determine its ductility and the soundness of weld. In this test a sufficient length of full-size pipe is bent cold through 90° around a cylindrical mandrel having a diameter 12 times the nominal diameter of the pipe. For close coiling, the pipe is bent cold through 180° around a mandrel having a diameter 8 times the nominal diameter of the pipe.

A2.5.1.7 *Transverse Guided Bend Test of Welds*—This bend test is used to determine the ductility of fusion welds. The specimens used are approximately 1 1/2 in. (38 mm) wide, at least 6 in. (152 mm) in length with the weld at the center, and are machined in accordance with Fig. 29(a) for face and root bend tests and in accordance with Fig. 29(b) for side bend tests. The dimensions of the plunger shall be as shown in Fig. 30 and the other dimensions of the bending jig shall be substantially as given in this same figure. A test shall consist of a face bend specimen and a root bend specimen or two side bend specimens. A face bend test requires bending with the inside surface of the pipe against the plunger; a root bend test requires bending with the outside surface of the pipe against the plunger; and a side bend test requires bending so that one of the side surfaces becomes the convex surface of the bend specimen.

(a) Failure of the bend test depends upon the appearance of cracks in the area of the bend, of the nature and extent described in the product specifications.

A3. STEEL FASTENERS

A3.1 Scope

A3.1.1 This supplement covers definitions and methods of testing peculiar to steel fasteners which are not covered in the general section of Test Methods and Definitions A 370. Standard tests required by the individual product specifications are to be performed as outlined in the general section of these methods.

A3.1.2 These tests are set up to facilitate production control testing and acceptance testing with certain more precise tests to be used for arbitration in case of disagreement over test results.

A3.2 Tension Tests

A3.2.1 It is preferred that bolts be tested full size, and it is

customary, when so testing bolts to specify a minimum ultimate load in pounds, rather than a minimum ultimate strength in pounds per square inch. Three times the bolt nominal diameter has been established as the minimum bolt length subject to the tests described in the remainder of this section. Sections A3.2.1.1 through A3.2.1.3 apply when testing bolts full size. Section A3.2.1.4 shall apply where the individual product specifications permit the use of machined specimens.

A3.2.1.1 *Proof Load*—Due to particular uses of certain classes of bolts it is desirable to be able to stress them, while in use, to a specified value without obtaining any permanent set. To be certain of obtaining this quality the proof load is specified. The proof load test consists of stressing the bolt

with a specified load which the bolt must withstand without permanent set. An alternate test which determines yield strength of a full size bolt is also allowed. Either of the following Methods, 1 or 2, may be used but Method 1 shall be the arbitration method in case of any dispute as to acceptance of the bolts.

A3.2.1.2 Proof Load Testing Long Bolts—When full size tests are required, proof load Method 1 is to be limited in application to bolts whose length does not exceed 8 in. (203 mm) or 8 times the nominal diameter, whichever is greater. For bolts longer than 8 in. or 8 times the nominal diameter, whichever is greater, proof load Method 2 shall be used.

(a) **Method 1, Length Measurement**—The overall length of a straight bolt shall be measured at its true center line with an instrument capable of measuring changes in length of 0.0001 in. (0.0025 mm) with an accuracy of 0.0001 in. in any 0.001-in. (0.025-mm) range. The preferred method of measuring the length shall be between conical centers machined on the center line of the bolt, with mating centers on the measuring anvils. The head or body of the bolt shall be marked so that it can be placed in the same position for all measurements. The bolt shall be assembled in the testing equipment as outlined in A3.2.1.4, and the proof load specified in the product specification shall be applied. Upon release of this load the length of the bolt shall be again measured and shall show no permanent elongation. A tolerance of ±0.0005 in. (0.0127 mm) shall be allowed between the measurement made before loading and that made after loading. Variables, such as straightness and thread alignment (plus measurement error), may result in apparent elongation of the fasteners when the proof load is initially applied. In such cases, the fastener may be retested using a 3 percent greater load, and may be considered satisfactory if the length after this loading is the same as before this loading (within the 0.0005-in. tolerance for measurement error).

A3.2.1.3 Proof Load-Time of Loading—The proof load is to be maintained for a period of 10 s before release of load, when using Method 1.

(a) **Method 2, Yield Strength**—The bolt shall be assembled in the testing equipment as outlined in A3.2.1.4. As the load is applied, the total elongation of the bolt or any part of the bolt which includes the exposed six threads shall be measured and recorded to produce a load-strain or a stress-strain diagram. The load or stress at an offset equal to 0.2 percent of the length of bolt occupied by 6 full threads shall be determined by the method described in 13.2.1 of these methods, A 370. This load or stress shall not be less than that prescribed in the product specification.

A3.2.1.4 Axial Tension Testing of Full Size Bolts—Bolts are to be tested in a holder with the load axially applied between the head and a nut or suitable fixture (Fig. 31), either of which shall have sufficient thread engagement to develop the full strength of the bolt. The nut or fixture shall be assembled on the bolt leaving six complete bolt threads unengaged between the grips, except for heavy hexagon structural bolts which shall have four complete threads unengaged between the grips. To meet the requirements of this test there shall be a tensile failure in the body or threaded section with no failure at the junction of the body, and head. If it is necessary to record or report the tensile strength of

bolts as psi values the stress area shall be calculated from the mean of the mean root and pitch diameters of Class 3 external threads as follows:

$$A_s = 0.7854[D - (0.9743/n)]^2$$

where:

A_s = stress area, in.²,

D = nominal diameter, in., and

n = number of threads per inch.

A3.2.1.5 Tension Testing of Full-Size Bolts with a Wedge—The purpose of this test is to obtain the tensile strength and demonstrate the “head quality” and ductility of a bolt with a standard head by subjecting it to eccentric loading. The ultimate load on the bolt shall be determined as described in A3.2.1.4, except that a 10° wedge shall be placed under the same bolt previously tested for the proof load (see A3.2.1.1). The bolt head shall be so placed that no corner of the hexagon or square takes a bearing load, that is, a flat of the head shall be aligned with the direction of uniform thickness of the wedge (Fig. 32). The wedge shall have an included angle of 10° between its faces and shall have a thickness of one-half of the nominal bolt diameter at the short side of the hole. The hole in the wedge shall have the following clearance over the nominal size of the bolt, and its edges, top and bottom, shall be rounded to the following radius:

Nominal Bolt Size, in.	Clearance in Hole, in. (mm)	Radius on Corners of Hole, in. (mm)
¼ to ½	0.030 (0.76)	0.030 (0.76)
⅝ to ¾	0.050 (1.3)	0.060 (1.5)
¾ to 1	0.063 (1.5)	0.060 (1.5)
1¼ to 1½	0.063 (1.5)	0.125 (3.2)
1½ to 1½	0.094 (2.4)	0.125 (3.2)

A3.2.1.6 Wedge Testing of HT Bolts Threaded to Head—For heat-treated bolts over 100 000 psi (690 MPa) minimum tensile strength and that are threaded 1 diameter and closer to the underside of the head, the wedge angle shall be 6° for sizes ¼ through ¾ in. (6.35 to 19.0 mm) and 4° for sizes over ¾ in.

A3.2.1.7 Tension Testing of Bolts Machined to Round Test Specimens:

(a) Bolts under 1½ in. (38 mm) in diameter which require machined tests shall preferably use a standard ½-in., (13-mm) round 2-in. (51-mm) gage length test specimen (Fig. 5); however, bolts of small cross-section that will not permit the taking of this standard test specimen shall use one of the small-size-specimens-proportional-to-standard (Fig. 5) and the specimen shall have a reduced section as large as possible. In all cases, the longitudinal axis of the specimen shall be concentric with the axis of the bolt; the head and threaded section of the bolt may be left intact, as in Figs. 35 and 36, or shaped to fit the holders or grips of the testing machine so that the load is applied axially. The gage length for measuring the elongation shall be four times the diameter of the specimen.

(b) For bolts 1½ in. and over in diameter, a standard ½-in. round 2-in. gage length test specimen shall be turned from the bolt, having its axis midway between the center and outside surface of the body of the bolt as shown in Fig. 35.

(c) Machined specimens are to be tested in tension to determine the properties prescribed by the product specifica-

tions. The methods of testing and determination of properties shall be in accordance with Section 13 of these test methods.

A3.3 Speed of Testing

A3.3.1 Speed of testing shall be as prescribed in the individual product specifications.

A3.4 Hardness Tests for Bolts

A3.4.1 When specified, the bolts shall meet a hardness test. The Brinell or Rockwell hardness test is usually taken on the side or top of the bolt head. For final arbitration the hardness shall be taken on a transverse section through the threaded section of the bolt at a point one-quarter of the nominal diameter from the axis of the bolt. This section shall be taken at a distance from the end of the bolt which is equivalent to the diameter of the bolt. Due to possible distortion from the Brinell load, care shall be taken to see that this test meets all the provisions of 17.2 of the general section of these methods. Where the Brinell hardness test is impractical, the Rockwell hardness test shall be substituted. Rockwell hardness test procedures shall conform to Section 18 of these methods.

A3.5 Testing of Nuts

A3.5.1 *Proof Load*—A sample nut shall be assembled on

a hardened threaded mandrel or on a bolt conforming to the particular specification. A load axial with the mandrel or bolt and equal to the specified proof load of the nut shall be applied. The nut shall resist this load without stripping or rupture. If the threads of the mandrel are damaged during the test the individual test shall be discarded. The mandrel shall be threaded to American National Standard Class 3 tolerance, except that the major diameter shall be the minimum major diameter with a tolerance of +0.002 in. (0.051 mm).

A3.5.2 *Hardness Test*—Rockwell hardness of nuts shall be determined on the top or bottom face of the nut. Brinell hardness shall be determined on the side of the nuts. Either method may be used at the option of the manufacturer, taking into account the size and grade of the nuts under test. When the standard Brinell hardness test results in deforming the nut it will be necessary to use a minor load or substitute a Rockwell hardness test.

A3.6 Bars Heat Treated or Cold Drawn for Use in the Manufacture of Studs, Nuts or Other Bolting Material

A3.6.1 When the bars, as received by the manufacturer, have been processed and proved to meet certain specified properties, it is not necessary to test the finished product when these properties have not been changed by the process of manufacture employed for the finished product.

A4. ROUND WIRE PRODUCTS

A4.1 Scope

A4.1.1 This supplement covers the apparatus, specimens and methods of testing peculiar to steel wire products which are not covered in the general section of Test Methods A 370.

A4.2 Apparatus

A4.2.1 *Gripping Devices*—Grips of either the wedge or snubbing types as shown in Figs. 36 and 37 shall be used (Note 19). When using grips of either type, care shall be taken that the axis of the test specimen is located approximately at the center line of the head of the testing machine (Note 20). When using wedge grips the liners used behind the grips shall be of the proper thickness.

NOTE 19—Testing machines usually are equipped with wedge grips. These wedge grips, irrespective of the type of testing machine, may be referred to as the "usual type" of wedge grips. The use of fine (180 or 240) grit abrasive cloth in the "usual" wedge type grips, with the abrasive contacting the wire specimen, can be helpful in reducing specimen slipping and breakage at the grip edges at tensile loads up to about 1000 pounds. For tests of specimens of wire which are liable to be cut at the edges by the "usual type" of wedge grips, the snubbing type gripping device has proved satisfactory.

For testing round wire, the use of cylindrical seat in the wedge gripping device is optional.

NOTE 20—Any defect in a testing machine which may cause nonaxial application of load should be corrected.

A4.2.2 *Pointed Micrometer*—A micrometer with a pointed spindle and anvil suitable for reading the dimensions of the wire specimen at the fractured ends to the nearest 0.001 in. (0.025 mm) after breaking the specimen in the testing machine shall be used.

A4.3 Test Specimens

A4.3.1 Test specimens having the full cross-sectional area of the wire they represent shall be used. The standard gage length of the specimens shall be 10 in. (254 mm). However, if the determination of elongation values is not required, any convenient gage length is permissible. The total length of the specimens shall be at least equal to the gage length (10 in.) plus twice the length of wire required for the full use of the grip employed. For example, depending upon the type of testing machine and grips used, the minimum total length of specimen may vary from 14 to 24 in. (360 to 610 mm) for a 10-in. gage length specimen.

A4.3.2 Any specimen breaking in the grips shall be discarded and a new specimen tested.

A4.4 Elongation

A4.4.1 In determining permanent elongation, the ends of the fractured specimen shall be carefully fitted together and the distance between the gage marks measured to the nearest 0.01 in. (0.25 mm) with dividers and scale or other suitable device. The elongation is the increase in length of the gage length, expressed as a percentage of the original gage length. In recording elongation values, both the percentage increase and the original gage length shall be given.

A4.4.2 In determining total elongation (elastic plus plastic extension) autographic or extensometer methods may be employed.

A4.4.3 If fracture takes place outside of the middle third of the gage length, the elongation value obtained may not be representative of the material.

A4.5 Reduction of Area

A4.5.1 The ends of the fractured specimen shall be carefully fitted together and the dimensions of the smallest cross section measured to the nearest 0.001 in. (0.025 mm) with a pointed micrometer. The difference between the area thus found and the area of the original cross section, expressed as a percentage of the original area, is the reduction of area.

A4.5.2 The reduction of area test is not recommended in wire diameters less than 0.092 in. (2.34 mm) due to the difficulties of measuring the reduced cross sections.

A4.6 Rockwell Hardness Test

A4.6.1 With the exception of heat-treated wire of diameter 0.100 in. (2.54 mm) and larger, the Rockwell hardness test is not recommended for round wire. On such heat-treated wire the specimen shall be flattened on two parallel sides by grinding. For round wire the tensile strength test is greatly to be preferred to the Rockwell hardness test.

4.7 Wrap Test

A4.7.1 This test is used as a means for testing the ductility of certain kinds of wire.

A4.7.2 The test consists of coiling the wire in a closely spaced helix tightly against a mandrel of a specified diameter for a required number of turns. (Unless other specified, the required number of turns shall be five.) The wrapping may be done by hand or a power device. The wrapping rate may not exceed 15 turns per min. The mandrel diameter shall be specified in the relevant wire product specification.

A4.7.3 The wire tested shall be considered to have failed if the wire fractures or if any longitudinal or transverse cracks develop which can be seen by the unaided eye after the first complete turn. Wire which fails in the first turn shall be retested, as such fractures may be caused by bending the wire to a radius less than specified when the test starts.

A4.8 Coiling Test

A4.8.1 This test is used to determine if imperfections are present to the extent that they may cause cracking or splitting during spring coiling and spring extension. A coil of specified length is closed wound on an arbor of a specified diameter. The closed coil is then stretched to a specified permanent increase in length and examined for uniformity of pitch with no splits or fractures. The required arbor diameter, closed coil length, and permanent coil extended length increase may vary with wire diameter, properties, and type.

A5. NOTES ON SIGNIFICANCE OF NOTCHED-BAR IMPACT TESTING

A5.1 Notch Behavior

A5.1.1 The Charpy and Izod type tests bring out notch behavior (brittleness versus ductility) by applying a single overload of stress. The energy values determined are quantitative comparisons on a selected specimen but cannot be converted into energy values that would serve for engineering design calculations. The notch behavior indicated in an individual test applies only to the specimen size, notch geometry, and testing conditions involved and cannot be generalized to other sizes of specimens and conditions.

A5.1.2 The notch behavior of the face-centered cubic metals and alloys, a large group of nonferrous materials and the austenitic steels can be judged from their common tensile properties. If they are brittle in tension they will be brittle when notched, while if they are ductile in tension, they will be ductile when notched, except for unusually sharp or deep notches (much more severe than the standard Charpy or Izod specimens). Even low temperatures do not alter this characteristic of these materials. In contrast, the behavior of the ferritic steels under notch conditions cannot be predicted from their properties as revealed by the tension test. For the study of these materials the Charpy and Izod type tests are accordingly very useful. Some metals that display normal ductility in the tension test may nevertheless break in brittle fashion when tested or when used in the notched condition. Notched conditions include restraints to deformation in directions perpendicular to the major stress, or multiaxial stresses, and stress concentrations. It is in this field that the Charpy and Izod tests prove useful for determining the susceptibility of a steel to notch-brittle behavior though they cannot be directly used to appraise the serviceability of a structure.

A5.1.3 The testing machine itself must be sufficiently rigid or tests on high-strength low-energy materials will result in excessive elastic energy losses either upward through the pendulum shaft or downward through the base of the machine. If the anvil supports, the pendulum striking edge, or the machine foundation bolts are not securely fastened, tests on ductile materials in the range of 80 ft·lbf (108 J) may actually indicate values in excess of 90 to 100 ft·lbf (122 to 136 J).

A5.2 Notch Effect

A5.2.1 The notch results in a combination of multiaxial stresses associated with restraints to deformation in directions perpendicular to the major stress, and a stress concentration at the base of the notch. A severely notched condition is generally not desirable, and it becomes of real concern in those cases in which it initiates a sudden and complete failure of the brittle type. Some metals can be deformed in a ductile manner even down to the low temperatures of liquid air, while others may crack. This difference in behavior can be best understood by considering the cohesive strength of a material (or the property that holds it together) and its relation to the yield point. In cases of brittle fracture, the cohesive strength is exceeded before significant plastic deformation occurs and the fracture appears crystalline. In cases of the ductile or shear type of failure, considerable deformation precedes the final fracture and the broken surface appears fibrous instead of crystalline. In intermediate cases the fracture comes after a moderate amount of deformation and is part crystalline and part fibrous in appearance.

A5.2.2 When a notched bar is loaded, there is a normal stress across the base of the notch which tends to initiate

fracture. The property that keeps it from cleaving, or holds it together, is the "cohesive strength." The bar fractures when the normal stress exceeds the cohesive strength. When this occurs without the bar deforming it is the condition for brittle fracture.

A5.2.3 In testing, though not in service because of side effects, it happens more commonly that plastic deformation precedes fracture. In addition to the normal stress, the applied load also sets up shear stresses which are about 45° to the normal stress. The elastic behavior terminates as soon as the shear stress exceeds the shear strength of the material and deformation or plastic yielding sets in. This is the condition for ductile failure.

A5.2.4 This behavior, whether brittle or ductile, depends on whether the normal stress exceeds the cohesive strength before the shear stress exceeds the shear strength. Several important facts of notch behavior follow from this. If the notch is made sharper or more drastic, the normal stress at the root of the notch will be increased in relation to the shear stress and the bar will be more prone to brittle fracture (see Table A5.1). Also, as the speed of deformation increases, the shear strength increases and the likelihood of brittle fracture increases. On the other hand, by raising the temperature, leaving the notch and the speed of deformation the same, the shear strength is lowered and ductile behavior is promoted, leading to shear failure.

A5.2.5 Variations in notch dimensions will seriously affect the results of the tests. Tests on E 4340 steel specimens⁹ have shown the effect of dimensional variations on Charpy results (see Table A5.1).

A5.3 Size Effect

A5.3.1 Increasing either the width or the depth of the specimen tends to increase the volume of metal subject to distortion, and by this factor tends to increase the energy absorption when breaking the specimen. However, any increase in size, particularly in width, also tends to increase the degree of restraint and by tending to induce brittle fracture, may decrease the amount of energy absorbed. Where a standard-size specimen is on the verge of brittle fracture, this is particularly true, and a double-width specimen may actually require less energy for rupture than one of standard width.

A5.3.2 In studies of such effects where the size of the material precludes the use of the standard specimen, as for example when the material is 1/4-in. plate, subsize specimens are necessarily used. Such specimens (see Fig. 6 of Methods E 23) are based on the Type A specimen of Fig. 4 of Methods E 23.

A5.3.3 General correlation between the energy values obtained with specimens of different size or shape is not feasible, but limited correlations may be established for specification purposes on the basis of special studies of particular materials and particular specimens. On the other hand, in a study of the relative effect of process variations, evaluation by use of some arbitrarily selected specimen with some chosen notch will in most instances place the methods in their proper order.

A5.4 Effects of Testing Conditions

A5.4.1 The testing conditions also affect the notch behavior. So pronounced is the effect of temperature on the behavior of steel when notched that comparisons are frequently made by examining specimen fractures and by plotting energy value and fracture appearance versus temperature from tests of notched bars at a series of temperatures. When the test temperature has been carried low enough to start cleavage fracture, there may be an extremely sharp drop in impact value or there may be a relatively gradual falling off toward the lower temperatures. This drop in energy value starts when a specimen begins to exhibit some crystalline appearance in the fracture. The transition temperature at which this embrittling effect takes place varies considerably with the size of the part or test specimen and with the notch geometry.

A5.4.2 Some of the many definitions of transition temperature currently being used are: (1) the lowest temperature at which the specimen exhibits 100 % fibrous fracture, (2) the temperature where the fracture shows a 50 % crystalline and a 50 % fibrous appearance, (3) the temperature corresponding to the energy value 50 % of the difference between values obtained at 100 % and 0 % fibrous fracture, and (4) the temperature corresponding to a specific energy value.

A5.4.3 A problem peculiar to Charpy-type tests occurs when high-strength, low-energy specimens are tested at low temperatures. These specimens may not leave the machine in the direction of the pendulum swing but rather in a sidewise direction. To ensure that the broken halves of the specimens do not rebound off some component of the machine and contact the pendulum before it completes its swing, modifications may be necessary in older model machines. These modifications differ with machine design. Nevertheless the basic problem is the same in that provisions must be made to prevent rebounding of the fractured specimens into any part of the swinging pendulum. Where design permits, the broken specimens may be deflected out of the sides of the machine and yet in other designs it may be necessary to contain the broken specimens within a certain area until the pendulum passes through the anvils. Some low-energy high-strength steel specimens leave impact machines at speeds in excess of 50 ft (15.3 m)/s although they were struck by a pendulum traveling at speeds approximately 17 ft (5.2 m)/s. If the force exerted on the pendulum by the broken specimens is sufficient, the pendulum will slow down and erroneously high energy values will be recorded. This problem accounts for many of the inconsistencies in Charpy results reported by various investigators within the 10 to 25-ft·lbf (14 to 34 J) range. The Apparatus Section (the paragraph regarding Specimen Clearance) of Methods E 23 discusses the two basic machine designs and a modification found to be satisfactory in minimizing jamming.

A5.5 Velocity of Straining

A5.5.1 Velocity of straining is likewise a variable that affects the notch behavior of steel. The impact test shows somewhat higher energy absorption values than the static tests above the transition temperature and yet, in some instances, the reverse is true below the transition temperature.

⁹ Fahey, N. H., "Effects of Variables in Charpy Impact Testing," *Materials Research & Standards*, Vol. 1, No. 11, November, 1961, p. 872.

A5.6 Correlation with Service

A5.6.1 While Charpy or Izod tests may not directly predict the ductile or brittle behavior of steel as commonly used in large masses or as components of large structures, these tests can be used as acceptance tests of identity for different lots of the same steel or in choosing between different steels, when correlation with reliable service behavior has been established. It may be necessary to make the

tests at properly chosen temperatures other than room temperature. In this, the service temperature or the transition temperature of full-scale specimens does not give the desired transition temperatures for Charpy or Izod tests since the size and notch geometry may be so different. Chemical analysis, tension, and hardness tests may not indicate the influence of some of the important processing factors that affect susceptibility to brittle fracture nor do they comprehend the effect of low temperatures in inducing brittle behavior.

A6. PROCEDURE FOR CONVERTING PERCENTAGE ELONGATION OF A STANDARD ROUND TENSION TEST SPECIMEN TO EQUIVALENT PERCENTAGE ELONGATION OF A STANDARD FLAT SPECIMEN

A6.1 Scope

A6.1.1 This method specifies a procedure for converting percentage elongation after fracture obtained in a standard 0.500-in. (12.7-mm) diameter by 2-in. (51-mm) gage length test specimen to standard flat test specimens 1/2 in. by 2 in. and 1 1/2 in. by 8 in. (38.1 by 203 mm).

A6.2 Basic Equation

A6.2.1 The conversion data in this method are based on an equation by Bertella,¹⁰ and used by Oliver¹¹ and others. The relationship between elongations in the standard 0.500-in. diameter by 2.0-in. test specimen and other standard specimens can be calculated as follows:

$$e = e_o [4.47 (\sqrt{A})/L]^a$$

where:

- e_o = percentage elongation after fracture on a standard test specimen having a 2-in. gage length and 0.500-in. diameter,
- e = percentage elongation after fracture on a standard test specimen having a gage length L and a cross-sectional area A , and
- a = constant characteristic of the test material.

A6.3 Application

A6.3.1 In applying the above equation the constant a is characteristic of the test material. The value $a = 0.4$ has been found to give satisfactory conversions for carbon, carbon-manganese, molybdenum, and chromium-molybdenum steels within the tensile strength range of 40,000 to 85,000 psi

(275 to 585 MPa) and in the hot-rolled, in the hot-rolled and normalized, or in the annealed condition, with or without tempering. Note that the cold reduced and quenched and tempered states are excluded. For annealed austenitic stainless steels, the value $a = 0.127$ has been found to give satisfactory conversions.

A6.3.2 Table A6.1 has been calculated taking $a = 0.4$, with the standard 0.500-in. (12.7-mm) diameter by 2-in. (51-mm) gage length test specimen as the reference specimen. In the case of the subsize specimens 0.350 in. (8.89 mm) in diameter by 1.4-in. (35.6-mm) gage length, and 0.250-in. (6.35-mm) diameter by 1.0-in. (25.4-mm) gage length the factor in the equation is 4.51 instead of 4.47. The small error introduced by using Table A6.1 for the subsize specimens may be neglected. Table A6.2 for annealed austenitic steels has been calculated taking $a = 0.127$, with the standard 0.500-in. diameter by 2-in. gage length test specimen as the reference specimen.

A6.3.3 Elongation given for a standard 0.500-in. diameter by 2-in. gage length specimen may be converted to elongation for 1/2 in. by 2 in. or 1 1/2 in. by 8 in. (38.1 by 203-mm) flat specimens by multiplying by the indicated factor in Tables A6.1 and A6.2.

A6.3.4 These elongation conversions shall not be used where the width to thickness ratio of the test piece exceeds 20, as in sheet specimens under 0.025 in. (0.635 mm) in thickness.

A6.3.5 While the conversions are considered to be reliable within the stated limitations and may generally be used in specification writing where it is desirable to show equivalent elongation requirements for the several standard ASTM tension specimens covered in Test Methods A 370, consideration must be given to the metallurgical effects dependent on the thickness of the material as processed.

A7. METHOD OF TESTING UNCOATED SEVEN-WIRE STRESS-RELIEVED STRAND FOR PRESTRESSED CONCRETES

A7.1 Scope

A7.1.1 This method provides procedures for the tension testing of uncoated seven-wire stress-relieved strand for prestressed concrete. This method is intended for use in evaluating the strand for the properties prescribed in Specification A 416.

A7.2 General Precautions

A7.2.1 Premature failure of the test specimens may result if there is any appreciable notching, cutting, or bending of the specimen by the gripping devices of the testing machine.

A7.2.2 Errors in testing may result if the seven wires constituting the strand are not loaded uniformly.

A7.2.3 The mechanical properties of the strand may be

¹⁰ Bertella, C. A., *Giornale del Genio Civile*, Vol 60, 1922, p. 343.

¹¹ Oliver, D. A., *Proceedings of the Institution of Mechanical Engineers*, 1928, p. 827.

materially affected by excessive heating during specimen preparation.

A7.2.4 These difficulties may be minimized by following the suggested methods of gripping described in A7.4.

A7.3 Gripping Devices

A7.3.1 The true mechanical properties of the strand are determined by a test in which fracture of the specimen occurs in the free span between the jaws of the testing machine. Therefore, it is desirable to establish a test procedure with suitable apparatus which will consistently produce such results. Due to inherent physical characteristics of individual machines, it is not practical to recommend a universal gripping procedure that is suitable for all testing machines. Therefore, it is necessary to determine which of the methods of gripping described in A7.3.2 to A7.3.8 is most suitable for the testing equipment available.

A7.3.2 *Standard V-Grips with Serrated Teeth (Note 22).*

A7.3.3 *Standard V-Grips with Serrated Teeth (Note 22), Using Cushioning Material*—In this method, some material is placed between the grips and the specimen to minimize the notching effect of the teeth. Among the materials which have been used are lead foil, aluminum foil, carborundum cloth, bra shims, etc. The type and thickness of material required is dependent on the shape, condition, and coarseness of the teeth.

A7.3.4 *Standard V-Grips with Serrated Teeth (Note 22), Using Special Preparation of the Gripped Portions of the Specimen*—One of the methods used is tinning, in which the gripped portions are cleaned, fluxed, and coated by multiple dips in molten tin alloy held just above the melting point. Another method of preparation is encasing the gripped portions in metal tubing or flexible conduit, using epoxy resin as the bonding agent. The encased portion should be approximately twice the length of lay of the strand.

A7.3.5 *Special Grips with Smooth, Semi-Cylindrical Grooves (Note 21)*—The grooves and the gripped portions of the specimen are coated with an abrasive slurry which holds the specimen in the smooth grooves, preventing slippage. The slurry consists of abrasive such as Grade 3-F aluminum oxide and a carrier such as water or glycerin.

A7.3.6 *Standard Sockets of the Type Used for Wire Rope*—The gripped portions of the specimen are anchored in the sockets with zinc. The special procedures for socketing usually employed in the wire rope industry must be followed.

A7.3.7 *Dead-End Eye Splices*—These devices are available in sizes designed to fit each size of strand to be tested.

A7.3.8 *Chucking Devices*—Use of chucking devices of the type generally employed for applying tension to strands in casting beds is not recommended for testing purposes.

NOTE 21—The number of teeth should be approximately 15 to 30 per in., and the minimum effective gripping length should be approximately 4 in. (102 mm).

NOTE 22—The radius of curvature of the grooves is approximately the same as the radius of the strand being tested, and is located $\frac{1}{32}$ in.

(0.79 mm) above the flat face of the grip. This prevents the two grips from closing tightly when the specimen is in place.

A7.4 Specimen Preparation

A7.4.1 Nonuniform loading of the seven wires in the strand may result if slippage of the individual wires of the strand, either the outside wire or the center wire, occur during the tension test. Wire slippage may be minimized by fusing together the cut ends of the specimen. This fusing can be concurrent with torch cutting of the specimens.

A7.4.2 If the molten-metal temperatures employed during hot-dip tinning or socketing with metallic material are too high, over approximately 700°F (370°C), the specimen may be heat affected with a subsequent loss of strength and ductility. Careful temperature controls should be maintained if such methods of specimen preparation are used.

A7.5 Procedure

A7.5.1 *Yield Strength*—For determining the yield strength use a Class B-1 extensometer (Note 23) as described in Practice E 83. Apply an initial load of 10 % of the expected minimum breaking strength to the specimen, then attach the extensometer and adjust it to a reading of 0. in./in. of gage length. Then increase the load until the extensometer indicates an extension of 1 %. Record the load for this extension as the yield strength. The extensometer may be removed from the specimen after the yield strength has been determined.

A7.5.2 *Elongation*—For determining the elongation use a Class D extensometer (Note 23), as described in Practice E 83, having a gage length of not less than 24 in. (610 mm) (Note 24). Apply an initial load of 10 % of the required minimum breaking strength to the specimen, then attach the extensometer (Note 23) and adjust it to a zero reading. The extensometer may be removed from the specimen prior to rupture after the specified minimum elongation has been exceeded. It is not necessary to determine the final elongation value.

A7.5.3 *Breaking Strength*—Determine the maximum load at which one or more wires of the strand are fractured. Record this load as the breaking strength of the strand.

NOTE 23—The yield-strength extensometer and the elongation extensometer may be the same instrument or two separate instruments. Two separate instruments are advisable since the more sensitive yield-strength extensometer, which could be damaged when the strand fractures, may be removed following the determination of yield strength. The elongation extensometer may be constructed with less sensitive parts or be constructed in such a way that little damage would result if fracture occurs while the extensometer is attached to the specimen.

NOTE 24—Specimens that break outside the extensometer or in the jaws and yet meet the minimum specified values are considered as meeting the mechanical property requirements of the product Specification A 416, regardless of what procedure of gripping has been used. Specimens that break outside of the extensometer or in the jaws and do not meet the minimum specified values are subject to retest in accordance with Specification A 416. Specimens that break between the jaws of the extensometer and do not meet the minimum specified values are subject to retest as provided in Section 14 of Specification A 416.

A8. ROUNDING OF TEST DATA

A8.1 Rounding

A8.1.1 An observed value or a calculated value shall be

rounded off in accordance with the applicable product specification. In the absence of a specified procedure, the

rounding-off method of Practice E 29 shall be used.

A8.1.1.1 Values shall be rounded up or rounded down as determined by the rules of Practice E 29.

A8.1.1.2 In the special case of rounding the number "5" when no additional numbers other than "0" follow the "5," rounding shall be done in the direction of the specification limits if following Practice E 29 would cause rejection of material.

A8.1.2 Recommended levels for rounding reported values

of test data are given in Table A8.1. These values are designed to provide uniformity in reporting and data storage, and should be used in all cases except where they conflict with specific requirements of a product specification.

NOTE 25—To minimize cumulative errors, whenever possible, values should be carried to at least one figure beyond that of the final (rounded) value during intervening calculations (such as calculation of stress from load and area measurements) with rounding occurring as the final operation. The precision may be less than that implied by the number of significant figures.

A9. METHODS FOR TESTING STEEL REINFORCING BARS

A9.1 Scope

A9.1.1 This supplement covers definitions and methods of testing steel reinforcing bars for use in concrete reinforcement which are not covered in the general section of this standard.

A9.2 Test Specimens

A9.2.1 Test specimens shall be the full section of the bar as rolled.

A9.3 Tension Testing

A9.3.1 The yield strength or yield point shall be determined by one of the following methods:

A9.3.1.1 Extension under load using an autographic diagram method or an extensometer as described in 13.1.2 and 13.1.3,

A9.3.1.2 By the drop of the beam or halt in the gage of the testing machine as described in 13.1.1 where the steel tested as a sharp-kneed or well-defined type of yield point.

A9.3.2 The unit stress determinations for yield and tensile strength on full-size specimens shall be based on the nominal bar area.

A9.4 Bend Testing

A9.4.1 Bend tests shall be made on specimens of sufficient length to ensure free bending and with apparatus which provides:

A9.4.1.1 Continuous and uniform application of force throughout the duration of the bending operation,

A9.4.1.2 Unrestricted movement of the specimen at points of contact with the apparatus and bending around a pin free to rotate, and

A9.4.1.3 Close wrapping of the specimen around the pin during the bending operation.

A9.4.2 Other acceptable more severe methods of bend testing, such as placing a specimen across two pins free to rotate and applying the bending force with a fix pin, may be used.

A9.4.3 When re-testing is permitted by the product specification, the following shall apply:

A9.4.3.1 Sections of bar containing identifying roll marking shall not be used.

A9.4.3.2 Bars shall be so placed that longitudinal ribs lie in a plane at right angles to the plane of bending.

A10. PROCEDURE FOR USE AND CONTROL OF HEAT-CYCLE SIMULATION

A10.1 Purpose

A10.1.1 To assure consistent and reproducible heat treatments of production forgings and the test specimens that represent them when the practice of heat-cycle simulation is used.

A10.2 Scope

A10.2.1 Generation and documentation of actual production time—temperature curves (MASTER CHARTS).

A10.2.2 Controls for duplicating the master cycle during heat treatment of production forgings. (Heat treating within the essential variables established during A1.2.1.).

A10.2.3 Preparation of program charts for the simulator unit.

A10.2.4 Monitoring and inspection of the simulated cycle within the limits established by the ASME Code.

A10.2.5 Documentation and storage of all controls, inspections, charts, and curves.

A10.3 Referenced Documents

A10.3.1 *ASME Standards*:¹²

ASME Boiler and Pressure Vessel Code Section III, latest edition.

ASME Boiler and Pressure Vessel Code Section VIII, Division 2, latest edition.

A10.4 Terminology

A10.4.1 *Definitions*:

A10.4.1.1 *master chart*—a record of the heat treatment received from a forging essentially identical to the production forgings that it will represent. It is a chart of time and temperature showing the output from thermocouples imbedded in the forging at the designated test immersion and test location or locations.

A10.4.1.2 *program chart*—the metallized sheet used to program the simulator unit. Time-temperature data from the master chart are manually transferred to the program chart.

¹² Available from American Society of Mechanical Engineers, 345 E. 47th St., New York, NY 10017

A10.4.1.3 *simulator chart*—a record of the heat treatment that a test specimen had received in the simulator unit. It is a chart of time and temperature and can be compared directly to the master chart for accuracy of duplication.

A10.4.1.4 *simulator cycle*—one continuous heat treatment of a set of specimens in the simulator unit. The cycle includes heating from ambient, holding at temperature, and cooling. For example, a simulated austenitize and quench of a set of specimens would be one cycle; a simulated temper of the same specimens would be another cycle.

A10.5 Procedure

A10.5.1 Production Master Charts:

A10.5.1.1 Thermocouples shall be imbedded in each forging from which a master chart is obtained. Temperature shall be monitored by a recorder with resolution sufficient to clearly define all aspects of the heating, holding, and cooling process. All charts are to be clearly identified with all pertinent information and identification required for maintaining permanent records.

A10.5.1.2 Thermocouples shall be imbedded 180 deg apart if the material specification requires test locations 180 deg apart.

A10.5.1.3 One master chart (or two if required in accordance with A10.5.1.2) shall be produced to represent essentially identical forgings (same size and shape). Any change in size or geometry (exceeding rough machining tolerances) of a forging will necessitate that a new master cooling curve be developed.

A10.5.1.4 If more than one curve is required per master forging (180 deg apart) and a difference in cooling rate is achieved, then the most conservative curve shall be used as the master curve.

A10.5.2 Reproducibility of Heat Treatment Parameters on Production Forgings:

A10.5.2.1 All information pertaining to the quench and temper of the master forging shall be recorded on an appropriate permanent record, similar to the one shown in Table A10.1.

A10.5.2.2 All information pertaining to the quench and temper of the production forgings shall be appropriately recorded, preferably on a form similar to that used in A10.5.2.1. Quench records of production forgings shall be retained for future reference. The quench and temper record of the master forging shall be retained as a permanent record.

A10.5.2.3 A copy of the master forging record shall be stored with the heat treatment record of the production forging.

A10.5.2.4 The essential variables, as set forth on the heat treat record, shall be controlled within the given parameters on the production forging.

A10.5.2.5 The temperature of the quenching medium prior to quenching each production forging shall be equal to or lower than the temperature of the quenching medium prior to quenching the master forging.

A10.5.2.6 The time elapsed from opening the furnace door to quench for the production forging shall not exceed that elapsed for the master forging.

A10.5.2.7 If the time parameter is exceeded in opening the furnace door to beginning of quench, the forging shall be

placed back into the furnace and brought back up to equalization temperature.

A10.5.2.8 All forgings represented by the same master forging shall be quenched with like orientation to the surface of the quench bath.

A10.5.2.9 All production forgings shall be quenched in the same quench tank, with the same agitation as the master forging.

A10.5.2.10 *Uniformity of Heat Treat Parameters*—(1) The difference in actual heat treating temperature between production forgings and the master forging used to establish the simulator cycle for them shall not exceed $\pm 25^{\circ}\text{F}$ ($\pm 14^{\circ}\text{C}$) for the quench cycle. (2) The tempering temperature of the production forgings shall not fall below the actual tempering temperature of the master forging. (3) At least one contact surface thermocouple shall be placed on each forging in a production load. Temperature shall be recorded for all surface thermocouples on a Time Temperature Recorder and such records shall be retained as permanent documentation.

A10.5.3 Heat-Cycle Simulation:

A10.5.3.1 Program charts shall be made from the data recorded on the master chart. All test specimens shall be given the same heating rate above, the AC1, the same holding time and the same cooling rate as the production forgings.

A10.5.3.2 The heating cycle above the AC1, a portion of the holding cycle, and the cooling portion of the master chart shall be duplicated and the allowable limits on temperature and time, as specified in (a)–(c), shall be established for verification of the adequacy of the simulated heat treatment.

(a) *Heat Cycle Simulation of Test Coupon Heat Treatment for Quenched and Tempered Forgings and Bars*—If cooling rate data for the forgings and bars and cooling rate control devices for the test specimens are available, the test specimens may be heat-treated in the device.

(b) The test coupons shall be heated to substantially the same maximum temperature as the forgings or bars. The test coupons shall be cooled at a rate similar to and no faster than the cooling rate representative of the test locations and shall be within 25°F (14°C) and 20 s at all temperatures after cooling begins. The test coupons shall be subsequently heat treated in accordance with the thermal treatments below the critical temperature including tempering and simulated post weld heat treatment.

(c) *Simulated Post Weld Heat Treatment of Test Specimens* (for ferritic steel forgings and bars)—Except for carbon steel (P Number 1, Section IX of the Code) forgings and bars with a nominal thickness or diameter of 2 in. (51 mm) or less, the test specimens shall be given a heat treatment to simulate any thermal treatments below the critical temperature that the forgings and bars may receive during fabrication. The simulated heat treatment shall utilize temperatures, times, and cooling rates as specified on the order. The total time at temperature(s) for the test material shall be at least 80 % of the total time at temperature(s) to which the forgings and bars are subjected during postweld heat treatment. The total time at temperature(s) for the test specimens may be performed in a single cycle.

A10.5.3.3 Prior to heat treatment in the simulator unit, test specimens shall be machined to standard sizes that have

been determined to allow adequately for subsequent removal of decarb and oxidation.

A10.5.3.4 At least one thermocouple per specimen shall be used for continuous recording of temperature on an independent external temperature-monitoring source. Due to the sensitivity and design peculiarities of the heating chamber of certain equipment, it is mandatory that the hot junctions of control and monitoring thermocouples always be placed in the same relative position with respect to the heating source (generally infra red lamps).

A10.5.3.5 Each individual specimen shall be identified, and such identification shall be clearly shown on the simulator chart and simulator cycle record.

A10.5.3.6 The simulator chart shall be compared to the master chart for accurate reproduction of simulated quench in accordance with A1.5.3.2(a). If any one specimen is not heat treated within the acceptable limits of temperature and time, such specimen shall be discarded and replaced by a newly machined specimen. Documentation of such action and reasons for deviation from the master chart shall be shown on the simulator chart, and on the corresponding nonconformance report.

A10.5.4 Reheat Treatment and Retesting:

A10.5.4.1 In the event of a test failure, retesting shall be handled in accordance with rules set forth by the material specification.

A10.5.4.2 If retesting is permissible, a new test specimen

shall be heat treated the same as previously. The production forging that it represents will have received the same heat treatment. If the test passes, the forging shall be acceptable. If it fails, the forging shall be rejected or shall be subject to reheat treatment if permissible.

A10.5.4.3 If reheat treatment is permissible, proceed as follows: (1) Reheat treatment same as original heat treatment (time, temperature, cooling rate): Using new test specimens from an area as close as possible to the original specimens, repeat the austenitize and quench cycles twice, followed by the tempering cycle (double quench and temper). The production forging shall be given the identical double quench and temper as its test specimens above. (2) Reheat treatment using a new heat treatment practice. Any change in time, temperature, or cooling rate shall constitute a new heat treatment practice. A new master curve shall be produced and the simulation and testing shall proceed as originally set forth.

A10.5.4.4 In summation, each test specimen and its corresponding forging shall receive identical heat treatment or heat treatment; otherwise the testing shall be invalid.

A10.5.5 Storage, Recall, and Documentation of Heat-Cycle Simulation Data—All records pertaining to heat-cycle simulation shall be maintained and held for a period of 10 years or as designed by the customer. Information shall be so organized that all practices can be verified by adequate documented records.

TABLE 1 Multiplying Factors to Be Used for Various Diameters of Round Test Specimens

Standard Specimen			Small Size Specimens Proportional to Standard					
0.500 in. Round			0.350 in. Round			0.250 in. Round		
Actual Diameter, in.	Area, in. ²	Multiplying Factor	Actual Diameter, in.	Area, in. ²	Multiplying Factor	Actual Diameter, in.	Area, in. ²	Multiplying Factor
0.490	0.1886	5.30	0.343	0.0924	10.82	0.245	0.0471	21.21
0.491	0.1893	5.28	0.344	0.0929	10.76	0.246	0.0475	21.04
0.492	0.1901	5.26	0.345	0.0935	10.70	0.247	0.0479	20.87
0.493	0.1909	5.24	0.346	0.0940	10.64	0.248	0.0483	20.70
0.494	0.1917	5.22	0.347	0.0946	10.57	0.249	0.0487	20.54
0.495	0.1924	5.20	0.348	0.0951	10.51	0.250	0.0491	20.37
0.496	0.1932	5.18	0.349	0.0957	10.45	0.251	0.0495	20.21
							(0.05) ^A	(20.0) ^A
0.497	0.1940	5.15	0.350	0.0962	10.39	0.252	0.0499	20.05
							(0.05) ^A	(20.0) ^A
0.498	0.1948	5.13	0.351	0.0968	10.33	0.253	0.0503	19.89
							(0.05) ^A	(20.0) ^A
0.499	0.1956	5.11	0.352	0.0973	10.28	0.254	0.0507	19.74
0.500	0.1963	5.09	0.353	0.0979	10.22	0.255	0.0511	19.58
0.501	0.1971	5.07	0.354	0.0984	10.16			
0.502	0.1979	5.05	0.355	0.0990	10.10			
0.503	0.1987	5.03	0.356	0.0995	10.05			
					(0.1) ^A			(10.0) ^A
0.504	0.1995	5.01	0.357	0.1001	9.99			
	(0.2) ^A	(5.0) ^A		(0.1) ^A	(10.0) ^A			
0.505	0.2003	4.99						
	(0.2) ^A	(5.0) ^A						
0.506	0.2011	4.97						
	(0.2) ^A	(5.0) ^A						
0.507	0.2019	4.95						
0.508	0.2027	4.93						
0.509	0.2035	4.91						
0.510	0.2043	4.90						

^A The values in parentheses may be used for ease in calculation of stresses, in pounds per square inch, as permitted in Note 5 of Fig. 4.

TABLE 2A Approximate Hardness Conversion Numbers for Non-austenitic Steels^a (Rockwell C to other Hardness Numbers)

Rockwell C Scale, 150-kgf Load, Diamond Penetrator	Vickers Hardness Number	Brinell Hardness, 3000-kgf Load, 10-mm Ball	Knoop Hardness, 500-gf Load and Over	Rockwell A Scale, 60-kgf Load, Diamond Penetrator	Rockwell Superficial Hardness			Approximate Tensile Strength, ksi (MPa)
					15N Scale, 15-kgf Load, Diamond Penetrator	30N Scale 30-kgf Load, Diamond Penetrator	45N Scale, 45-kgf Load, Diamond Penetrator	
68	940	...	920	85.6	93.2	84.4	75.4	...
67	900	...	895	85.0	92.9	83.6	74.2	...
66	865	...	870	84.5	92.5	82.8	73.3	...
65	832	739	846	83.9	92.2	81.9	72.0	...
64	800	722	822	83.4	91.8	81.1	71.0	...
63	772	706	799	82.8	91.4	80.1	69.9	...
62	746	688	776	82.3	91.1	79.3	68.8	...
61	720	670	754	81.8	90.7	78.4	67.7	...
60	697	654	732	81.2	90.2	77.5	66.6	...
59	674	634	710	80.7	89.8	76.6	65.5	...
58	653	615	690	80.1	89.3	75.7	64.3	351 (2420)
57	633	595	670	79.6	88.9	74.8	63.2	338 (2330)
56	613	577	650	79.0	88.3	73.9	62.0	325 (2240)
55	595	560	630	78.5	87.9	73.0	60.9	313 (2160)
54	577	543	612	78.0	87.4	72.0	60.9	301 (2070)
53	560	525	594	77.4	86.9	71.2	59.8	292 (2010)
52	544	512	576	76.8	86.4	70.2	58.6	283 (1950)
51	528	496	558	76.3	85.9	69.4	57.4	273 (1880)
50	513	482	542	75.9	85.5	68.5	56.1	264 (1820)
49	498	468	526	75.2	85.0	67.6	55.0	255 (1760)
48	484	455	510	74.7	84.5	66.7	53.8	246 (1700)
47	471	442	495	74.1	83.9	65.8	52.5	238 (1640)
46	458	432	480	73.6	83.5	64.8	51.4	229 (1580)
45	446	421	466	73.1	83.0	64.0	50.3	221 (1520)
44	434	409	452	72.5	82.5	63.1	49.0	215 (1480)
43	423	400	438	72.0	82.0	62.2	47.8	208 (1430)
42	412	390	426	71.5	81.5	61.3	46.7	201 (1390)
41	402	381	414	70.9	80.9	60.4	45.5	194 (1340)
40	392	371	402	70.4	80.4	59.5	44.3	188 (1300)
39	382	362	391	69.9	79.9	58.6	43.1	182 (1250)
38	372	353	380	69.4	79.4	57.7	41.9	177 (1220)
37	363	344	370	68.9	78.8	56.8	40.8	171 (1180)
36	354	336	360	68.4	78.3	55.9	39.6	166 (1140)
35	345	327	351	67.9	77.7	55.0	38.4	161 (1110)
34	336	319	342	67.4	77.2	54.2	37.2	156 (1080)
33	327	311	334	66.8	76.6	53.3	36.1	152 (1050)
32	318	301	326	66.3	76.1	52.1	34.9	149 (1030)
31	310	294	318	65.8	75.6	51.3	33.7	146 (1010)
30	302	286	311	65.3	75.0	50.4	32.5	141 (970)
29	294	279	304	64.6	74.5	49.5	31.3	138 (950)
28	286	271	297	64.3	73.9	48.6	30.1	135 (930)
27	279	264	290	63.8	73.3	47.7	28.9	131 (900)
26	272	258	284	63.3	72.8	46.8	27.8	128 (880)
25	266	253	278	62.8	72.2	46.8	26.7	125 (860)
24	260	247	272	62.4	71.6	45.9	25.5	123 (850)
23	254	243	266	62.0	71.0	45.0	24.3	119 (820)
22	248	237	261	61.5	70.5	44.0	23.1	117 (810)
21	243	231	256	61.0	69.9	43.2	22.0	115 (790)
20	238	226	251	60.5	69.4	42.3	20.7	112 (770)
						41.5	19.6	110 (760)

^a This table gives the approximate interrelationships of hardness values and approximate tensile strength of steels. It is possible that steels of various compositions and processing histories will deviate in hardness-tensile strength relationship from the data presented in this table. The data in this table should not be used for austenitic stainless steels, but have been shown to be applicable for ferritic and martensitic stainless steels. Where more precise conversions are required, they should be developed specially for each steel composition, heat treatment, and part.

TABLE 2B Approximate Hardness Conversion Numbers for Non-austenitic Steels^a (Rockwell B to other Hardness Numbers)

Rockwell B Scale, 100-kgf Load 1/16-in. (1.588-mm) Ball	Vickers Hardness Number	Brinell Hardness, 3000-kgf Load, 10-mm Ball	Knoop Hardness, 500-gf Load and Over	Rockwell A Scale, 60-kgf Load, Diamond Penetrator	Rockwell F Scale, 60-kgf Load, 1/16-in. (1.588-mm) Ball	Rockwell Superficial Hardness			Approximate Tensile Strength ksi (MPa)
						15T Scale, 15-kgf Load, 1/16-in. (1.588- mm) Ball	30T Scale, 30-kgf Load, 1/16-in. (1.588- mm) Ball	45T Scale, 45-kgf Load, 1/16-in. (1.588- mm) Ball	
100	240	240	251	61.5	...	93.1	83.1	72.9	116 (800)
99	234	234	246	60.9	...	92.8	82.5	71.9	114 (785)
98	228	228	241	60.2	...	92.5	81.8	70.9	109 (750)
97	222	222	236	59.5	...	92.1	81.1	69.9	104 (715)
96	216	216	231	58.9	...	91.8	80.4	68.9	102 (705)
95	210	210	226	58.3	...	91.5	79.8	67.9	100 (690)
94	205	205	221	57.6	...	91.2	79.1	66.9	98 (675)
93	200	200	216	57.0	...	90.8	78.4	65.9	94 (650)
92	195	195	211	56.4	...	90.5	77.8	64.8	92 (635)
91	190	190	206	55.8	...	90.2	77.1	63.8	90 (620)
90	185	185	201	55.2	...	89.9	76.4	62.8	89 (615)
89	180	180	196	54.6	...	89.5	75.8	61.8	88 (605)
88	176	176	192	54.0	...	89.2	75.1	60.8	86 (590)
87	172	172	188	53.4	...	88.9	74.4	59.8	84 (580)
86	169	169	184	52.8	...	88.6	73.8	58.8	83 (570)
85	165	165	180	52.3	...	88.2	73.1	57.8	82 (565)
84	162	162	176	51.7	...	87.9	72.4	56.8	81 (560)
83	159	159	173	51.1	...	87.6	71.8	55.8	80 (550)
82	156	156	170	50.6	...	87.3	71.1	54.8	77 (530)
81	153	153	167	50.0	...	86.9	70.4	53.8	73 (505)
80	150	150	164	49.5	...	86.6	69.7	52.8	72 (495)
79	147	147	161	48.9	...	86.3	69.1	51.8	70 (485)
78	144	144	158	48.4	...	86.0	68.4	50.8	69 (475)
77	141	141	155	47.9	...	85.6	67.7	49.8	68 (470)
76	139	139	152	47.3	...	85.3	67.1	48.8	67 (460)
75	137	137	150	46.8	99.6	85.0	66.4	47.8	66 (455)
74	135	135	147	46.3	99.1	84.7	65.7	46.8	65 (450)
73	132	132	145	45.8	98.5	84.3	65.1	45.8	64 (440)
72	130	130	143	45.3	98.0	84.0	64.4	44.8	63 (435)
71	127	127	141	44.8	97.4	83.7	63.7	43.8	62 (425)
70	125	125	139	44.3	96.8	83.4	63.1	42.8	61 (420)
69	123	123	137	43.8	96.2	83.0	62.4	41.8	60 (415)
68	121	121	135	43.3	95.6	82.7	61.7	40.8	59 (405)
67	119	119	133	42.8	95.1	82.4	61.0	39.8	58 (400)
66	117	117	131	42.3	94.5	82.1	60.4	38.7	57 (395)
65	116	116	129	41.8	93.9	81.8	59.7	37.7	56 (385)
64	114	114	127	41.4	93.4	81.4	59.0	36.7	...
63	112	112	125	40.9	92.8	81.1	58.4	35.7	...
62	110	110	124	40.4	92.2	80.8	57.7	34.7	...
61	108	108	122	40.0	91.7	80.5	57.0	33.7	...
60	107	107	120	39.5	91.1	80.1	56.4	32.7	...
59	106	106	118	39.0	90.5	79.8	55.7	31.7	...
58	104	104	117	38.6	90.0	79.5	55.0	30.7	...
57	103	103	115	38.1	89.4	79.2	54.4	29.7	...
56	101	101	114	37.7	88.8	78.8	53.7	28.7	...
55	100	100	112	37.2	88.2	78.5	53.0	27.7	...
54	111	36.8	87.7	78.2	52.4	26.7	...
53	110	36.3	86.5	77.9	51.7	25.7	...
52	109	35.9	86.0	77.5	51.0	24.7	...
51	108	35.5	85.4	77.2	50.3	23.7	...
50	107	35.0	84.8	76.9	49.7	22.7	...
49	106	34.6	84.3	76.6	49.0	21.7	...
48	105	34.1	83.7	76.2	48.3	20.7	...
47	104	33.7	83.1	75.9	47.7	19.7	...
46	103	33.3	...	75.6	47.0	18.7	...

TABLE 2B *Continued*

Rockwell B Scale, 100-kgf Load 1/16-in. (1.588-mm) Ball	Vickers Hardness Number	Brinell Hardness, 3000-kgf Load, 10-mm Ball	Knoop Hardness, 500-gf Load and Over	Rockwell A Scale, 60-kgf Load, Diamond Penetrator	Rockwell F Scale, 60-kgf Load, 1/16-in. (1.588-mm) Ball	Rockwell Superficial Hardness			Approximate Tensile Strength ksi (MPa)
						15T Scale, 15-kgf Load, 1/16-in. (1.588-mm) Ball	30T Scale, 30-kgf Load, 1/16-in. (1.588-mm) Ball	45T Scale, 45-kgf Load, 1/16-in. (1.588-mm) Ball	
45	102	32.9	82.6	75.3	46.3	17.7	...
44	101	32.4	82.0	74.9	45.7	16.7	...
43	100	32.0	81.4	74.6	45.0	15.7	...
42	99	31.6	80.8	74.3	44.3	14.7	...
41	98	31.2	80.3	74.0	43.7	13.6	...
40	97	30.7	79.7	73.6	43.0	12.6	...
39	96	30.3	79.1	73.3	42.3	11.6	...
38	95	29.9	78.6	73.0	41.6	10.6	...
37	94	29.5	78.0	72.7	41.0	9.6	...
36	93	29.1	77.4	72.3	40.3	8.6	...
35	92	28.7	76.9	72.0	39.6	7.6	...
34	91	28.2	76.3	71.7	39.0	6.6	...
33	90	27.8	75.7	71.4	38.3	5.6	...
32	89	27.4	75.2	71.0	37.6	4.6	...
31	88	27.0	74.6	70.7	37.0	3.6	...
30	87	26.6	74.0	70.4	36.3	2.6	...

^ This table gives the approximate interrelationships of hardness values and approximate tensile strength of steels. It is possible that steels of various compositions and processing histories will deviate in hardness-tensile strength relationship from the data presented in this table. The data in this table should not be used for austenitic stainless steels, but have been shown to be applicable for ferritic and martensitic stainless steels. Where more precise conversions are required, they should be developed specially for each steel composition, heat treatment, and part.

TABLE 2C *Approximate Hardness Conversion Numbers for Austenitic Steels (Rockwell C to other Hardness Numbers)*

Rockwell C Scale, 150-kgf Load, Diamond Penetrator	Rockwell A Scale, 60-kgf Load, Diamond Penetrator	Rockwell Superficial Hardness		
		15N Scale, 15-kgf Load, Diamond Penetrator	30N Scale, 30-kgf Load, Diamond Penetrator	45N Scale, 45-kgf Load, Diamond Penetrator
48	74.4	84.1	66.2	52.1
47	73.9	83.6	65.3	50.9
46	73.4	83.1	64.5	49.8
45	72.9	82.6	63.6	48.7
44	72.4	82.1	62.7	47.5
43	71.9	81.6	61.8	46.4
42	71.4	81.0	61.0	45.2
41	70.9	80.5	60.1	44.1
40	70.4	80.0	59.2	43.0
39	69.9	79.5	58.4	41.8
38	69.3	79.0	57.5	40.7
37	68.8	78.5	56.6	39.6
36	68.3	78.0	55.7	38.4
35	67.8	77.5	54.9	37.3
34	67.3	77.0	54.0	36.1
33	66.8	76.5	53.1	35.0
32	66.3	75.9	52.3	33.9
31	65.8	75.4	51.4	32.7
30	65.3	74.9	50.5	31.6
29	64.8	74.4	49.6	30.4
28	64.3	73.9	48.8	29.3
27	63.8	73.4	47.9	28.2
26	63.3	72.9	47.0	27.0
25	62.8	72.4	46.2	25.9
24	62.3	71.9	45.3	24.8
23	61.8	71.3	44.4	23.6
22	61.3	70.8	43.5	22.5
21	60.8	70.3	42.7	21.3
20	60.3	69.8	41.8	20.2

TABLE 2D Approximate Hardness Conversion Numbers for Austenitic Steels (Rockwell B to other Hardness Numbers)

Rockwell B Scale, 100- kgf Load, 1/16- in. (1.588- mm) Ball	Brinell Indentation Diameter, mm	Brinell Hardness, 3000-kgf Load, 10-mm Ball	Rockwell A Scale, 60-kgf Load, Diamond Penetrator	Rockwell Superficial Hardness		
				15T Scale, 15-kgf Load, 1/16-in. (1.588- mm) Ball	30T Scale, 30-kgf Load, 1/16-in. (1.588- mm) Ball	45T Scale, 45-kgf Load, 1/16-in. (1.588- mm) Ball
100	3.79	256	61.5	91.5	80.4	70.2
99	3.85	248	60.9	91.2	79.7	69.2
98	3.91	240	60.3	90.8	79.0	68.2
97	3.96	233	59.7	90.4	78.3	67.2
96	4.02	226	59.1	90.1	77.7	66.1
95	4.08	219	58.5	89.7	77.0	65.1
94	4.14	213	58.0	89.3	76.3	64.1
93	4.20	207	57.4	88.9	75.6	63.1
92	4.24	202	56.8	88.6	74.9	62.1
91	4.30	197	56.2	88.2	74.2	61.1
90	4.35	192	55.6	87.8	73.5	60.1
89	4.40	187	55.0	87.5	72.8	59.0
88	4.45	183	54.5	87.1	72.1	58.0
87	4.51	178	53.9	86.7	71.4	57.0
86	4.55	174	53.3	86.4	70.7	56.0
85	4.60	170	52.7	86.0	70.0	55.0
84	4.65	167	52.1	85.6	69.3	54.0
83	4.70	163	51.5	85.2	68.6	52.9
82	4.74	160	50.9	84.9	67.9	51.9
81	4.79	156	50.4	84.5	67.2	50.9
80	4.84	153	49.8	84.1	66.5	49.9

TABLE 3 Brinell Hardness Numbers^A
(Ball 10 mm in Diameter, Applied Loads of 500, 1500, and 3000 kgf)

Diameter of Indentation, mm	Brinell Hardness Number			Diameter of Indentation, mm	Brinell Hardness Number			Diameter of Indentation, mm	Brinell Hardness Number			Diameter of Indentation, mm	Brinell Hardness Number		
	500-kgf Load	1500-kgf Load	3000-kgf Load		500-kgf Load	1500-kgf Load	3000-kgf Load		500-kgf Load	1500-kgf Load	3000-kgf Load		500-kgf Load	1500-kgf Load	3000-kgf Load
2.00	158	473	945	2.60	92.6	278	555	3.20	60.5	182	363	3.80	42.4	127	255
2.01	156	468	936	2.61	91.8	276	551	3.21	60.1	180	361	3.81	42.2	127	253
2.02	154	463	926	2.62	91.1	273	547	3.22	59.8	179	359	3.82	42.0	126	252
2.03	153	459	917	2.63	90.4	271	543	3.23	59.4	178	356	3.83	41.7	125	250
2.04	151	454	908	2.64	89.7	269	538	3.24	59.0	177	354	3.84	41.5	125	249
2.05	150	450	899	2.65	89.0	267	534	3.25	58.6	176	352	3.85	41.3	124	248
2.06	148	445	890	2.66	88.4	265	530	3.26	58.3	175	350	3.86	41.1	123	246
2.07	147	441	882	2.67	87.7	263	526	3.27	57.9	174	347	3.87	40.9	123	245
2.08	146	437	873	2.68	87.0	261	522	3.28	57.5	173	345	3.88	40.6	122	244
2.09	144	432	865	2.69	86.4	259	518	3.29	57.2	172	343	3.89	40.4	121	242
2.10	143	428	856	2.70	85.7	257	514	3.30	56.8	170	341	3.90	40.2	121	241
2.11	141	424	848	2.71	85.1	255	510	3.31	56.5	169	339	3.91	40.0	120	240
2.12	140	420	840	2.72	84.4	253	507	3.32	56.1	168	337	3.92	39.8	119	239
2.13	139	416	832	2.73	83.8	251	503	3.33	55.8	167	335	3.93	39.6	119	237
2.14	137	412	824	2.74	83.2	250	499	3.34	55.4	166	333	3.94	39.4	118	236
2.15	136	408	817	2.75	82.6	248	495	3.35	55.1	165	331	3.95	39.1	117	235
2.16	135	404	809	2.76	81.9	246	492	3.36	54.8	164	329	3.96	38.9	117	234
2.17	134	401	802	2.77	81.3	244	488	3.37	54.4	163	326	3.97	38.7	116	232
2.18	132	397	794	2.78	80.8	242	485	3.38	54.1	162	325	3.98	38.5	116	231
2.19	131	393	787	2.79	80.2	240	481	3.39	53.8	161	323	3.99	38.3	115	230
2.20	130	390	780	2.80	79.6	239	477	3.40	53.4	160	321	4.00	38.1	114	229
2.21	129	386	772	2.81	79.0	237	474	3.41	53.1	159	319	4.01	37.9	114	228
2.22	128	383	765	2.82	78.4	235	471	3.42	52.8	158	317	4.02	37.7	113	226
2.23	126	379	758	2.83	77.9	234	467	3.43	52.5	157	315	4.03	37.5	113	225
2.24	125	376	752	2.84	77.3	232	464	3.44	52.2	156	313	4.04	37.3	112	224
2.25	124	372	745	2.85	76.8	230	461	3.45	51.8	156	311	4.05	37.1	111	223
2.26	123	369	738	2.86	76.2	229	457	3.46	51.5	155	309	4.06	37.0	111	222
2.27	122	366	732	2.87	75.7	227	454	3.47	51.2	154	307	4.07	36.8	110	221
2.28	121	363	725	2.88	75.1	225	451	3.48	50.9	153	306	4.08	36.6	110	219
2.29	120	359	719	2.89	74.6	224	448	3.49	50.6	152	304	4.09	36.4	109	218
2.30	119	356	712	2.90	74.1	222	444	3.50	50.3	151	302	4.10	36.2	109	217
2.31	118	353	706	2.91	73.6	221	441	3.51	50.0	150	300	4.11	36.0	108	216
2.32	117	350	700	2.92	73.0	219	438	3.52	49.7	149	298	4.12	35.8	108	215
2.33	116	347	694	2.93	72.5	218	435	3.53	49.4	148	297	4.13	35.7	107	214
2.34	115	344	688	2.94	72.0	216	432	3.54	49.2	147	295	4.14	35.5	106	213
2.35	114	341	682	2.95	71.5	215	429	3.55	48.9	147	293	4.15	35.3	106	212
2.36	113	338	676	2.96	71.0	213	426	3.56	48.6	146	292	4.16	35.1	105	211
2.37	112	335	670	2.97	70.5	212	423	3.57	48.3	145	290	4.17	34.9	105	210
2.38	111	332	665	2.98	70.1	210	420	3.58	48.0	144	288	4.18	34.8	104	209
2.39	110	330	659	2.99	69.6	209	417	3.59	47.7	143	286	4.19	34.6	104	208
2.40	109	327	653	3.00	69.1	207	415	3.60	47.5	142	285	4.20	34.4	103	207
2.41	108	324	648	3.01	68.6	206	412	3.61	47.2	142	283	4.21	34.2	103	205
2.42	107	322	643	3.02	68.2	205	409	3.62	46.9	141	282	4.22	34.1	102	204
2.43	106	319	637	3.03	67.7	203	406	3.63	46.7	140	280	4.23	33.9	102	203
2.44	105	316	632	3.04	67.3	202	404	3.64	46.4	139	278	4.24	33.7	101	202
2.45	104	313	627	3.05	66.8	200	401	3.65	46.1	138	277	4.25	33.6	101	201
2.46	104	311	621	3.06	66.4	199	398	3.66	45.9	138	275	4.26	33.4	100	200
2.47	103	308	616	3.07	65.9	198	395	3.67	45.6	137	274	4.27	33.2	99.7	199
2.48	102	306	611	3.08	65.5	196	393	3.68	45.4	136	272	4.28	33.1	99.2	198
2.49	101	303	606	3.09	65.0	195	390	3.69	45.1	135	271	4.29	32.9	98.8	198
2.50	100	301	601	3.10	64.6	194	388	3.70	44.9	135	269	4.30	32.8	98.3	197
2.51	99.4	298	597	3.11	64.2	193	385	3.71	44.6	134	268	4.31	32.6	97.8	196
2.52	98.6	296	592	3.12	63.8	191	383	3.72	44.4	133	266	4.32	32.4	97.3	195
2.53	97.8	294	587	3.13	63.3	190	380	3.73	44.1	132	265	4.33	32.3	96.8	194
2.54	97.1	291	582	3.14	62.9	189	378	3.74	43.9	132	263	4.34	32.1	96.4	193
2.55	96.3	289	578	3.15	62.5	188	375	3.75	43.6	131	262	4.35	32.0	95.9	192
2.56	95.5	287	573	3.16	62.1	186	373	3.76	43.4	130	260	4.36	31.8	95.5	191
2.57	94.8	284	569	3.17	61.7	185	370	3.77	43.1	129	259	4.37	31.7	95.0	190
2.58	94.0	282	564	3.18	61.3	184	368	3.78	42.9	129	257	4.38	31.5	94.5	189
2.59	93.3	280	560	3.19	60.9	183	366	3.79	42.7	128	256	4.39	31.4	94.1	188

A 370

TABLE 4 Percent Shear for Measurements Made in Inches

NOTE—Since this table is set up for finite measurements or dimensions A and B, 100% shear is to be reported when either A or B is zero.

Dimension B, in.	Dimension A, in.																
	0.05	0.10	0.12	0.14	0.16	0.18	0.20	0.22	0.24	0.26	0.28	0.30	0.32	0.34	0.36	0.38	0.40
0.05	98	96	95	94	94	93	92	91	90	90	89	88	87	86	85	85	84
0.10	96	92	90	89	87	85	84	82	81	79	77	76	74	73	71	69	68
0.12	95	90	88	86	85	83	81	79	77	75	73	71	69	67	65	63	61
0.14	94	89	86	84	82	80	77	75	73	71	68	66	64	62	59	57	55
0.16	94	87	85	82	79	77	74	72	69	67	64	61	59	56	53	51	48
0.18	93	85	83	80	77	74	72	68	65	62	59	56	54	51	48	45	42
0.20	92	84	81	77	74	72	68	65	61	58	55	52	48	45	42	39	36
0.22	91	82	79	75	72	68	65	61	57	54	50	47	43	40	36	33	29
0.24	90	81	77	73	69	65	61	57	54	50	46	42	38	34	30	27	23
0.26	90	79	75	71	67	62	58	54	50	46	41	37	33	29	25	20	16
0.28	89	77	73	68	64	59	55	50	46	41	37	32	28	23	18	14	10
0.30	88	76	71	66	61	56	52	47	42	37	32	27	23	18	13	9	3
0.31	88	75	70	65	60	55	50	45	40	35	30	25	20	18	10	5	0

TABLE 5 Percent Shear for Measurements Made in Millimetres

NOTE—Since this table is set up for finite measurements or dimensions A and B, 100% shear is to be reported when either A or B is zero.

Dimension B, mm	Dimension A, mm																		
	1.0	1.5	2.0	2.5	3.0	3.5	4.0	4.5	5.0	5.5	6.0	6.5	7.0	7.5	8.0	8.5	9.0	9.5	10
1.0	99	98	98	97	96	96	95	94	94	93	92	92	91	91	90	89	89	88	88
1.5	98	97	96	95	94	93	92	92	91	90	89	88	87	86	85	84	83	82	81
2.0	98	96	95	94	92	91	90	89	88	86	85	84	82	81	80	79	77	76	75
2.5	97	95	94	92	91	89	88	86	84	83	81	79	77	75	73	72	70	69	69
3.0	96	94	92	91	89	87	85	83	81	79	77	76	74	72	70	68	66	64	62
3.5	96	93	91	89	87	85	82	80	78	76	74	72	69	67	65	63	61	58	56
4.0	95	92	90	88	85	82	80	77	75	72	70	67	65	62	60	57	55	52	50
4.5	94	92	89	86	83	80	77	75	72	69	66	63	61	58	55	52	49	46	44
5.0	94	91	88	85	81	78	75	72	69	66	62	59	56	53	50	47	44	41	37
5.5	93	90	86	83	79	76	72	69	66	62	59	55	52	48	45	42	38	35	31
6.0	92	89	85	81	77	74	70	66	62	59	55	51	47	44	40	36	33	29	25
6.5	92	88	84	80	76	72	67	63	59	55	51	47	43	39	35	31	27	23	19
7.0	91	87	82	78	74	69	65	61	56	52	47	43	39	34	30	26	21	17	12
7.5	91	86	81	77	72	67	62	58	53	48	44	39	34	30	25	20	16	11	6
8.0	90	85	80	75	70	65	60	55	50	45	40	35	30	25	20	15	10	5	0

TABLE 6 Charpy V-Notch Test Acceptance Criteria for Various Sub-Size Specimens⁴

Full Size, 10 by 10 mm		¾ Size, 10 by 7.5 mm		¾ Size, 10 by 6.7 mm		½ Size, 10 by 5 mm		½ Size, 10 by 3.3 mm		¼ Size, 10 by 2.5 mm	
ft·lbf	[J]	ft·lbf	[J]	ft·lbf	[J]	ft·lbf	[J]	ft·lbf	[J]	ft·lbf	[J]
40	[54]	30	[41]	27	[37]	20	[27]	13	[18]	10	[14]
35	[48]	26	[35]	23	[31]	18	[24]	12	[16]	9	[12]
30	[41]	22	[30]	20	[27]	15	[20]	10	[14]	8	[11]
25	[34]	19	[26]	17	[23]	12	[16]	8	[11]	6	[8]
20	[27]	15	[20]	13	[18]	10	[14]	7	[10]	5	[7]
16	[22]	12	[16]	11	[15]	8	[11]	5	[7]	4	[5]
15	[20]	11	[15]	10	[14]	8	[11]	5	[7]	4	[5]
13	[18]	10	[14]	9	[12]	6	[8]	4	[5]	3	[4]
12	[16]	9	[12]	8	[11]	6	[8]	4	[5]	3	[4]
10	[14]	8	[11]	7	[10]	5	[7]	3	[4]	2	[3]
7	[10]	5	[7]	5	[7]	4	[5]	2	[3]	2	[3]

⁴ Interpolation shall be made for specimens with widths intermediate of those listed. Interpolated values shall be rounded to the nearest whole number as prescribed in Practice E 29.

TABLE A1.1 Practices for Selecting Tension Test Specimens for Steel Bar Products

NOTE—For bar sections where it is difficult to determine the cross-sectional area by simple measurement, the area in square inches may be calculated by dividing the weight per linear inch of specimen in pounds by 0.2833 (weight of 1 in.³ of steel) or by dividing the weight per linear foot of specimen by 3.4 (weight of steel 1 in. square and 1 ft long).

Thickness, in. (mm)	Width, in. (mm)	Hot-Rolled Bars	
		Flats	Cold-Finished Bars
Under 3/8 (16)	Up to 1 1/2 (38), incl	Full section by 8-in. (203-mm) gage length (Fig. 4).	Mill reduced section to 2-in. (51-mm) gage length and approximately 25% less than test specimen width.
	Over 1 1/2 (38)	Full section, or mill to 1 1/2 in. (38 mm) wide by 8-in. (203-mm) gage length (Fig. 4).	Mill reduced section to 2-in. gage length and 1 1/2 in. wide.
3/8 to 1 1/2 (16 to 38), excl	Up to 1 1/2 (38), incl	Full section by 8-in. gage length or machine standard 1/2 by 2-in. (13 by 51-mm) gage length specimen from center of section (Fig. 5).	Mill reduced section to 2-in. (51-mm) gage length and approximately 25% less than test specimen width or machine standard 1/2 by 2-in. (13 by 51-mm) gage length specimen from center of section (Fig. 5).
	Over 1 1/2 (38)	Full section, or mill 1 1/2 in. (38 mm) width by 8-in. (203-mm) gage length (Fig. 4) or machine standard 1/2 by 2-in. gage (13 by 51-mm) gage length specimen from midway between edge and center of section (Fig. 5).	Mill reduced section to 2-in. gage length and 1 1/2 in. wide or machine standard 1/2 by 2-in. gage length specimen from midway between edge and center of section (Fig. 5).
1 1/2 (38) and over		Full section by 8-in. (203-mm) gage length, or machine standard 1/2 by 2-in. (13 by 51-mm) gage length specimen from midway between surface and center (Fig. 5).	Machine standard 1/2 by 2-in. (13 by 51-mm) gage length specimen from midway between surface and center (Fig. 5).
Rounds, Squares, Hexagons, and Octagons			
Diameter or Distance Between Parallel Faces, in. (mm)	Hot-Rolled Bars		Cold-Finished Bars
Under 3/8	Full section by 8-in. (203-mm) gage length on machine to sub-size specimen (Fig. 5).		Machine to sub-size specimen (Fig. 5).
3/8 to 1 1/2 (16 to 38), excl	Full section by 8-in. (203-mm) gage length or machine standard 1/2 in. by 2-in. (13 by 51-mm) gage length specimen from center of section (Fig. 5).		Machine standard 1/2 in. by 2-in. gage length specimen from center of section (Fig. 5).
1 1/2 (38) and over	Full section by 8-in. (203-mm) gage length or machine standard 1/2 in. by 2-in. (13 by 51-mm) gage length specimen from midway between surface and center of section (Fig. 5).		Machine standard 1/2 in. by 2-in. (13 by 51-mm) gage length specimen from midway between surface and center of section (Fig. 5).
Other Bar-Size Sections			
All sizes	Full section by 8-in. (203-mm) gage length or prepare test specimen 1 1/2 in. (38 mm) wide (if possible) by 8-in. (203-mm) gage length.		Mill reduced section to 2-in. (51-mm) gage length and approximately 25% less than test specimen width.

TABLE A1.2 Recommended Practice for Selecting Bend Test Specimens for Steel Bar Products

NOTE 1—The length of all specimens is to be not less than 6 in. (150 mm).
NOTE 2—The edges of the specimen may be rounded to a radius not exceeding 1/16 in. (1.6 mm).

Flats		
Thickness, in. (mm)	Width, in. (mm)	Recommended Size
Up to 1/2 (13), incl	Up to 3/4 (19), incl	Full section.
	Over 3/4 (19)	Full section or machine to not less than 3/4 in. (19 mm) in width by thickness of specimen.
Over 1/2 (13)	All	Full section or machine to 1 by 1/2 in. (25 by 13 mm) specimen from midway between center and surface.

TABLE A2.1 Wall Thickness Limitations of Superficial Hardness Test on Annealed or Ductile Materials for Steel Tubular Products^A ("T" Scale (1/16-in. Ball))

Wall Thickness, in. (mm)	Load, kgf
Over 0.050 (1.27)	45
Over 0.035 (0.89)	30
0.020 and over (0.51)	15

^A The heaviest load recommended for a given wall thickness is generally used.

TABLE A2.2 Wall Thickness Limitations of Superficial Hardness

TABLE A5.1 Effect of Varying Notch Dimensions on Standard Specimens

	High-Energy Specimens, ft·lbf (J)	High-Energy Specimens, ft·lbf (J)	Low-Energy Specimens, ft·lbf (J)
Specimen with standard dimensions	76.0 ± 3.8 (103.0 ± 5.2)	44.5 ± 2.2 (60.3 ± 3.0)	12.5 ± 1.0 (16.9 ± 1.4)
Depth of notch, 0.084 in. (2.13 mm) ^A	72.2 (97.9)	41.3 (56.0)	11.4 (15.5)
Depth of notch, 0.0805 in. (2.04 mm) ^A	75.1 (101.8)	42.2 (57.2)	12.4 (16.8)
Depth of notch, 0.0775 in. (1.77 mm) ^A	76.8 (104.1)	45.3 (61.4)	12.7 (17.2)
Depth of notch, 0.074 in. (1.57 mm) ^A	79.6 (107.9)	46.0 (62.4)	12.8 (17.3)
Radius at base of notch, 0.005 in. (0.127 mm) ^B	72.3 (98.0)	41.7 (56.5)	10.8 (14.6)
Radius at base of notch, 0.015 in. (0.381 mm) ^B	80.0 (108.5)	47.4 (64.3)	15.8 (21.4)

^A Standard 0.079 ± 0.002 in. (2.00 ± 0.05 mm).
^B Standard 0.010 ± 0.001 in. (0.25 ± 0.025 mm).

TABLE A6.1 Carbon and Alloy Steels—Material Constant $a = 0.4$. Multiplication Factors for Converting Percent Elongation from ½-in. Diameter by 2-in. Gage Length Standard Tension Test Specimen to Standard ½ by 2-in. and 1½ by 8-in. Flat Specimens

Thickness, in.	½ by 2-in. Specimen	1½ by 8-in. Specimen	Thickness in.	1½ by 8-in. Specimen
0.025	0.574	...	0.800	0.822
0.030	0.596	...	0.850	0.832
0.035	0.614	...	0.900	0.841
0.040	0.631	...	0.950	0.850
0.045	0.646	...	1.000	0.859
0.050	0.660	...	1.125	0.880
0.055	0.672	...	1.250	0.898
0.060	0.684	...	1.375	0.916
0.065	0.695	...	1.500	0.932
0.070	0.706	...	1.625	0.947
0.075	0.715	...	1.750	0.961
0.080	0.725	...	1.875	0.974
0.085	0.733	...	2.000	0.987
0.090	0.742	0.531	2.125	0.999
0.100	0.758	0.542	2.250	1.010
0.110	0.772	0.553	2.375	1.021
0.120	0.786	0.562	2.500	1.032
0.130	0.799	0.571	2.625	1.042
0.140	0.810	0.580	2.750	1.052
0.150	0.821	0.588	2.875	1.061
0.160	0.832	0.596	3.000	1.070
0.170	0.843	0.603	3.125	1.079
0.180	0.852	0.610	3.250	1.088
0.190	0.862	0.616	3.375	1.096
0.200	0.870	0.623	3.500	1.104
0.225	0.891	0.638	3.625	1.112
0.250	0.910	0.651	3.750	1.119
0.275	0.928	0.664	3.875	1.127
0.300	0.944	0.675	4.000	1.134
0.325	0.959	0.686
0.350	0.973	0.696
0.375	0.987	0.706
0.400	1.000	0.715
0.425	1.012	0.724
0.450	1.024	0.732
0.475	1.035	0.740
0.500	1.045	0.748
0.525	1.056	0.755
0.550	1.066	0.762
0.575	1.075	0.770
0.600	1.084	0.776
0.625	1.093	0.782
0.650	1.101	0.788
0.675	1.110
0.700	1.118	0.800
0.725	1.126
0.750	1.134	0.811

TABLE A6.2 Annealed Austenitic Stainless Steels—Material Constant $a = 0.127$. Multiplication Factors for Converting Percent Elongation from ½-in. Diameter by 2-in. Gage Length Standard Tension Test Specimen to Standard ½ by 2-in. and 1½ by 8-in. Flat Specimens

Thickness, in.	½ by 2-in. Specimen	1½ by 8-in. Specimen	Thickness, in.	1½ by 8-in. Specimen
0.025	0.839	...	0.800	0.940
0.030	0.848	...	0.850	0.943
0.035	0.857	...	0.900	0.947
0.040	0.864	...	0.950	0.950
0.045	0.870	...	1.000	0.953
0.050	0.876	...	1.125	0.960
0.055	0.882	...	1.250	0.966
0.060	0.886	...	1.375	0.972
0.065	0.891	...	1.500	0.978
0.070	0.895	...	1.625	0.983
0.075	0.899	...	1.750	0.987
0.080	0.903	...	1.875	0.992
0.085	0.906	...	2.000	0.996
0.090	0.909	0.818	2.125	1.000
0.095	0.913	0.821	2.250	1.003
0.100	0.916	0.823	2.375	1.007
0.110	0.921	0.828	2.500	1.010
0.120	0.926	0.833	2.625	1.013
0.130	0.931	0.837	2.750	1.016
0.140	0.935	0.841	2.875	1.019
0.150	0.940	0.845	3.000	1.022
0.160	0.943	0.848	3.125	1.024
0.170	0.947	0.852	3.250	1.027
0.180	0.950	0.855	3.375	1.029
0.190	0.954	0.858	3.500	1.032
0.200	0.957	0.860	3.625	1.034
0.225	0.964	0.867	3.750	1.036
0.250	0.970	0.873	3.875	1.038
0.275	0.976	0.878	4.000	1.041
0.300	0.982	0.883
0.325	0.987	0.887
0.350	0.991	0.892
0.375	0.996	0.895
0.400	1.000	0.899
0.425	1.004	0.903
0.450	1.007	0.906
0.475	1.011	0.909
0.500	1.014	0.912
0.525	1.017	0.915
0.550	1.020	0.917
0.575	1.023	0.920
0.600	1.026	0.922
0.625	1.029	0.925
0.650	1.031	0.927
0.675	1.034
0.700	1.036	0.932
0.725	1.038
0.750	1.041	0.936

TABLE A8.1 Recommended Values for Rounding Test Data

Test Quantity	Test Data Range	Rounded Value ^a
Yield Point, Yield Strength, Tensile Strength	up to 50 000 psi, excl (up to 50 ksi)	100 psi (0.1 ksi)
	50 000 to 100 000 psi, excl (50 to 100 ksi)	500 psi (0.5 ksi)
	100 000 psi and above (100 ksi and above)	1000 psi (1.0 ksi)
Elongation	up to 500 MPa, excl	1 MPa
	500 to 1000 MPa, excl	5 MPa
	1000 MPa and above	10 MPa
Reduction of Area	0 to 10 %, excl	0.5 %
	10 % and above	1 %
Impact Energy Brinell Hardness Rockwell Hardness	0 to 240 ft·lbf (or 0 to 325 J)	1 ft·lbf (or 1 J) ^b
	all values	tabular value ^c
	all scales	1 Rockwell Number

^a Round test data to the nearest integral multiple of the values in this column. If the data value is exactly midway between two rounded values, round in accordance with 37.1.2.

^b These units are not equivalent but the rounding occurs in the same numerical ranges for each, (1 ft·lbf = 1.356 J.)

^c Round the mean diameter of the Brinell impression to the nearest 0.05 mm and report the corresponding Brinell hardness number read from the table without further rounding.

TABLE A10.1 Heat-Treat Record-Essential Variables

	Master Forging	Production Forging 1	Production Forging 2	Production Forging 3	Production Forging 4	Production Forging 5
Program chart number						
Time at temperature and actual temperature of heat treatment						
Method of cooling						
Forging thickness						
Thermocouple immersion						
Beneath buffer (yes/no)						
Forging number						
Product						
Material						
Thermocouple location—0 deg						
Thermocouple location—180 deg						
Quench tank No.						
Date of heat treatment						
Furnace number						
Cycle number						
Heat treater						
Starting quench medium temperature						
Time from furnace to quench						
Heating rate above 1000°F (538°C)						
Temperature upon removal from quench after 5 min						
Orientation of forging in quench						

ASTM A 370

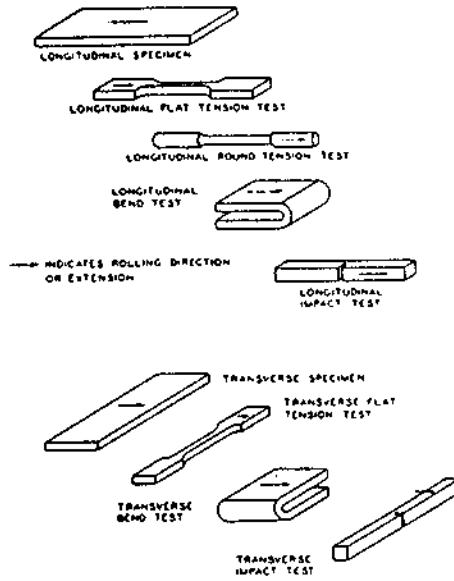
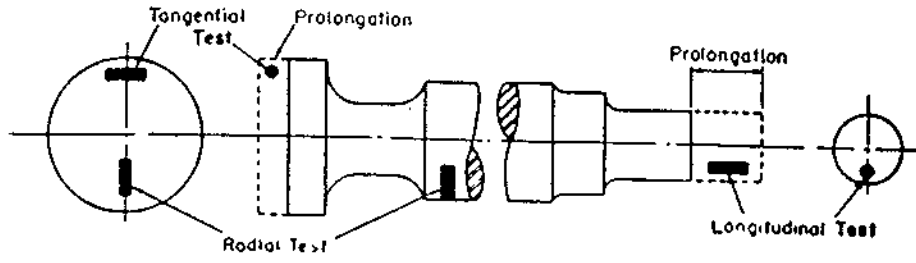
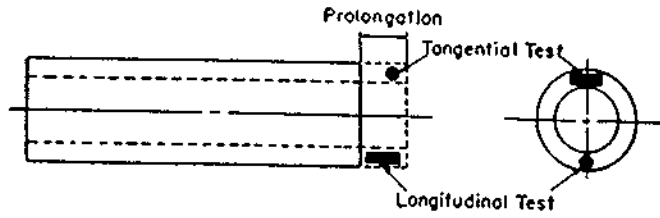

FIG. 1 The Relation of Test Coupons and Test Specimens to Rolling Direction or Extension (Applicable to General Wrought Products)



(a) Shafts and Rotors



(b) Hollow Forgings.

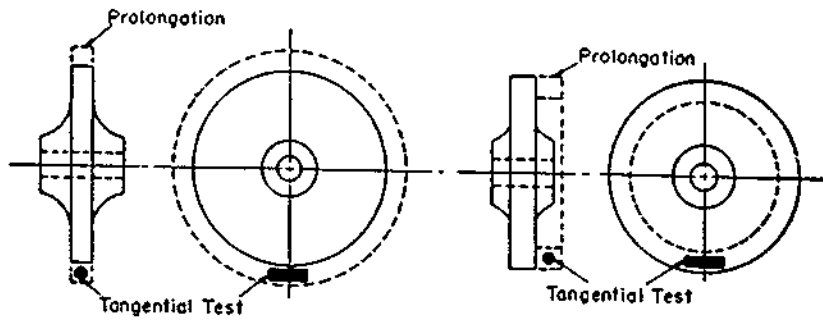

(c) Disk Forgings

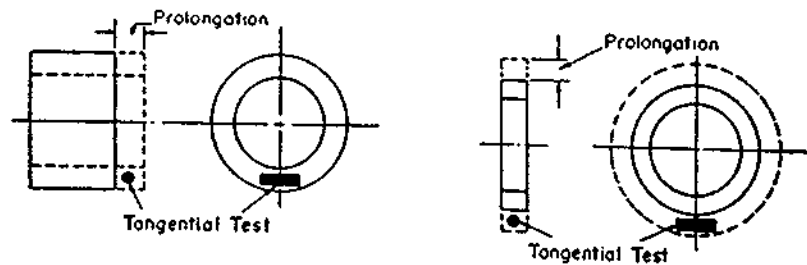

(d) Ring Forgings.

FIG. 2 Locations of Test Specimens for Various Types of Forgings

A 370

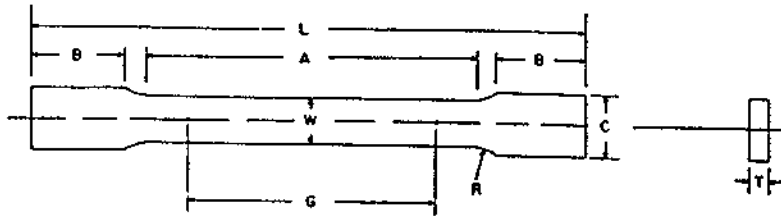

DIMENSIONS

	Standard Specimens				Subsize Specimen	
	Plate-Type, 1½-in. Wide		Sheet-Type, ½-in. Wide		¼-in. Wide	
	in.	mm	in.	mm	in.	mm
G—Gage length (Notes 1 and 2)	8.00 ± 0.01	200 ± 0.25	2.000 ± 0.005	50.0 ± 0.10	1.000 ± 0.003	25.0 ± 0.08
W—Width (Notes 3, 4, and 5)	1½ + ¼ - ¼	40 + 3 - 6	0.500 ± 0.010	12.5 ± 0.25	0.250 ± 0.002	6.25 ± 0.05
T—Thickness (Note 6)			thickness of material			
R—Radius of fillet, min	½	13	½	13	¼	6
L—Over-all length, min (Notes 2 and 7)	18	450	8	200	4	100
A—Length of reduced section, min	9	225	2¼	60	1¼	32
B—Length of grip section, min (Note 8)	3	75	2	50	1¼	32
C—Width of grip section, approximate (Notes 4, 9, and 10)	2	50	¾	20	¾	10

NOTE 1—For the 1½-in. (40-mm) wide specimen, punch marks for measuring elongation after fracture shall be made on the flat or on the edge of the specimen and within the reduced section. Either a set of nine or more punch marks 1 in. (25 mm) apart, or one or more pairs of punch marks 8 in. (200 mm) apart may be used.

NOTE 2—When elongation measurements of 1½-in. (40-mm) wide specimens are not required, a gage length (G) of 2.000 in. ± 0.005 in. (50.0 mm ± 0.10 mm) with all other dimensions similar to the plate-type specimen may be used.

NOTE 3—For the three sizes of specimens, the ends of the reduced section shall not differ in width by more than 0.004, 0.002 or 0.001 in. (0.10, 0.05 or 0.025 mm), respectively. Also, there may be a gradual decrease in width from the ends to the center, but the width at either end shall not be more than 0.015 in., 0.005 in., or 0.003 in. (0.40, 0.10 or 0.08 mm), respectively, larger than the width at the center.

NOTE 4—For each of the three sizes of specimens, narrower widths (W and C) may be used when necessary. In such cases the width of the reduced section should be as large as the width of the material being tested permits; however, unless stated specifically, the requirements for elongation in a product specification shall not apply when these narrower specimens are used. If the width of the material is less than W, the sides may be parallel throughout the length of the specimen.

NOTE 5—The specimen may be modified by making the sides parallel throughout the length of the specimen, the width and tolerances being the same as those specified above. When necessary a narrower specimen may be used, in which case the width should be as great as the width of the material being tested permits. If the width is 1½ in. (38 mm) or less, the sides may be parallel throughout the length of the specimen.

NOTE 6—The dimension T is the thickness of the test specimen as provided for in the applicable material specifications. Minimum nominal thickness of 1½-in. (40-mm) wide specimens shall be ¾ in. (5 mm), except as permitted by the product specification. Maximum nominal thickness of ½-in. (12.5-mm) and ¼-in. (6-mm) wide specimens shall be ¾ in. (19 mm) and ¼ in. (6 mm), respectively.

NOTE 7—To aid in obtaining axial loading during testing of ¼-in. (6-mm) wide specimens, the over-all length should be as the material will permit.

NOTE 8—It is desirable, if possible, to make the length of the grip section large enough to allow the specimen to extend into the grips a distance equal to two thirds or more of the length of the grips. If the thickness of ½-in. (13-mm) wide specimens is over ¾ in. (10 mm), longer grips and correspondingly longer grip sections of the specimen may be necessary to prevent failure in the grip section.

NOTE 9—For standard sheet-type specimens and subsize specimens the ends of the specimen shall be symmetrical with the center line of the reduced section within 0.01 and 0.005 in. (0.25 and 0.13 mm), respectively. However, for steel if the ends of the ½-in. (12.5-mm) wide specimen are symmetrical within 0.05 in. (1.0 mm) a specimen may be considered satisfactory for all but referee testing.

NOTE 10—For standard plate-type specimens the ends of the specimen shall be symmetrical with the center line of the reduced section within 0.25 in. (6.35 mm) except for referee testing in which case the ends of the specimen shall be symmetrical with the center line of the reduced section within 0.10 in. (2.5 mm).

FIG. 3 Rectangular Tension Test Specimens

A 370

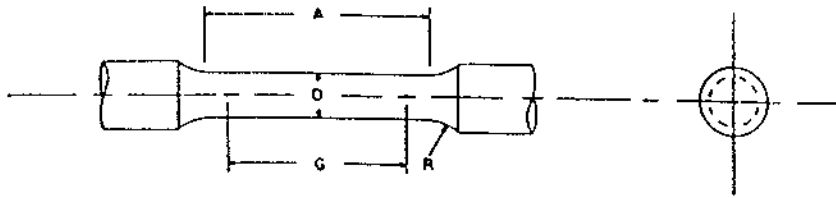

DIMENSIONS

Nominal Diameter	Standard Specimen		Small-Size Specimens Proportional to Standard							
	in.	mm	in.	mm	in.	mm	in.	mm	in.	mm
	0.500	12.5	0.350	8.75	0.250	6.25	0.160	4.00	0.113	2.50
G—Gage length	2.00 ± 0.005	50.0 ± 0.10	1.400 ± 0.005	35.0 ± 0.10	1.000 ± 0.005	25.0 ± 0.10	0.640 ± 0.005	16.0 ± 0.10	0.450 ± 0.005	10.0 ± 0.10
D—Diameter (Note 1)	0.500 ± 0.010	12.5 ± 0.25	0.350 ± 0.007	8.75 ± 0.18	0.250 ± 0.005	6.25 ± 0.12	0.160 ± 0.003	4.00 ± 0.08	0.113 ± 0.002	2.50 ± 0.05
R—Radius of fillet, min	3/8	10	1/4	6	3/16	5	5/32	4	3/32	2
A—Length of reduced section, min (Note 2)	2 1/4	60	1 3/4	45	1 1/4	32	3/4	20	5/8	16

NOTE 1—The reduced section may have a gradual taper from the ends toward the center, with the ends not more than 1 percent larger in diameter than the center (controlling dimension).

NOTE 2—If desired, the length of the reduced section may be increased to accommodate an extensometer of any convenient gage length. Reference marks for the measurement of elongation should, nevertheless, be spaced at the indicated gage length.

NOTE 3—The gage length and fillets shall be as shown, but the ends may be of any form to fit the holders of the testing machine in such a way that the load shall be axial (see Fig. 9). If the ends are to be held in wedge grips it is desirable, if possible, to make the length of the grip section great enough to allow the specimen to extend into the grips a distance equal to two thirds or more of the length of the grips.

NOTE 4—On the round specimens in Figs. 5 and 6, the gage lengths are equal to four times the nominal diameter. In some product specifications other specimens may be provided for, but unless the 4-to-1 ratio is maintained within dimensional tolerances, the elongation values may not be comparable with those obtained from the standard test specimen.

NOTE 5—The use of specimens smaller than 0.250-in. (6.25-mm) diameter shall be restricted to cases when the material to be tested is of insufficient size to obtain larger specimens or when all parties agree to their use for acceptance testing. Smaller specimens require suitable equipment and greater skill in both machining and testing.

NOTE 6—Five sizes of specimens often used have diameters of approximately 0.505, 0.357, 0.252, 0.160, and 0.113 in., the reason being to permit easy calculations of stress from loads, since the corresponding cross sectional areas are equal or close to 0.200, 0.100, 0.0500, 0.0200, and 0.0100 in.², respectively. Thus, when the actual diameters agree with these values, the stresses (or strengths) may be computed using the simple multiplying factors 5, 10, 20, 50, and 100, respectively. (The metric equivalents of these fixed diameters do not result in correspondingly convenient cross sectional area and multiplying factors.)

FIG. 4 Standard 0.500-in. (12.5-mm) Round Tension Test Specimen with 2-in. (50-mm) Gage Length and Examples of Small-Size Specimens Proportional to the Standard Specimens

A 370

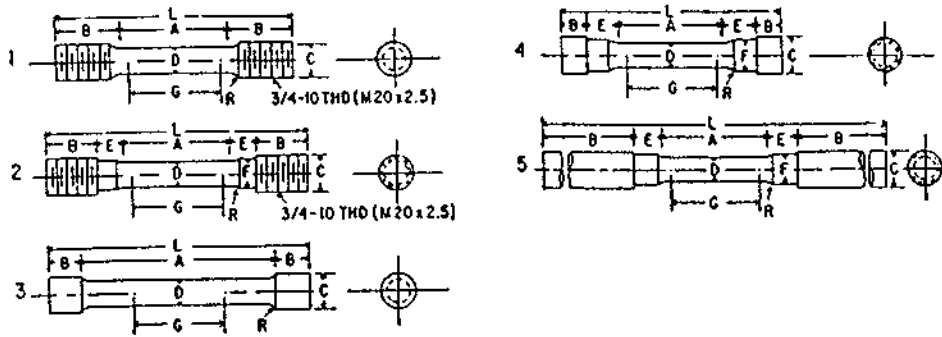

DIMENSIONS

	Specimen 1		Specimen 2		Specimen 3		Specimen 4		Specimen 5	
	in.	mm	in.	mm	in.	mm	in.	mm	in.	mm
G—Gage length	2.000 ± 0.005	50.0 ± 0.10	2.000 ± 0.005	50.0 ± 0.10	2.000 ± 0.005	50.0 ± 0.10	2.000 ± 0.005	50.0 ± 0.10	2.00 ± 0.005	50.0 ± 0.10
D—Diameter (Note 1)	0.500 ± 0.010	12.5 ± 0.25	0.500 ± 0.010	12.5 ± 0.25	0.500 ± 0.010	12.5 ± 0.25	0.500 ± 0.010	12.5 ± 0.25	0.500 ± 0.010	12.5 ± 0.25
R—Radius of fillet, min	3/8	10	3/8	10	1/8	2	3/8	10	3/8	10
A—Length of reduced section	2 1/4, min	60, min	2 1/4, min	60, min	4, approximately	100, approximately	2 1/4, min	60, min	2 1/4, min	60, min
L—Over-all length, approximate	5	125	5 1/2	140	5 1/2	140	4 3/4	120	9 1/2	240
B—Length of end section (Note 2)	1 3/8, approximately	35, approximately	1, approximately	25, approximately	3/4, approximately	20, approximately	1/2, approximately	13, approximately	3, min	75, min
C—Diameter of end section	3/4	20	3/4	20	23/32	18	3/8	22	3/4	20
E—Length of shoulder and fillet section, approximate	3/8	16	3/8	20	3/8	16
F—Diameter of shoulder	3/8	16	3/8	16	1 7/32	15

NOTE 1—The reduced section may have a gradual taper from the ends toward the center with the ends not more than 0.005 in. (0.10 mm) larger in diameter than the center.

NOTE 2—On Specimen 5 it is desirable, if possible, to make the length of the grip section great enough to allow the specimen to extend into the grips a distance equal to two thirds or more of the length of the grips.

NOTE 3—The types of ends shown are applicable for the standard 0.500-in. round tension test specimen; similar types can be used for subsize specimens. The use of UNF series of threads (3/4 by 16, 1/2 by 20, 3/8 by 24, and 1/4 by 28) is suggested for high-strength brittle materials to avoid fracture in the thread portion.

FIG. 5 Suggested Types of Ends for Standard Round Tension Test Specimens

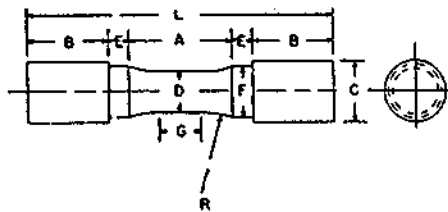

DIMENSIONS

	Specimen 1		Specimen 2		Specimen 3	
	in.	mm	in.	mm	in.	mm
G—Length of parallel	Shall be equal to or greater than diameter D					
D—Diameter	0.500 ± 0.010	12.5 ± 0.25	0.750 ± 0.015	20.0 ± 0.40	1.25 ± 0.025	30.0 ± 0.60
R—Radius of fillet, min	1	25	1	25	2	50
A—Length of reduced section, min	1 1/4	32	1 1/2	38	2 1/4	60
L—Over-all length, min	3 3/4	95	4	100	6 3/8	160
B—Length of end section, approximate	1	25	1	25	1 3/4	45
C—Diameter of end section, approximate	3/4	20	1 1/8	30	1 7/8	48
E—Length of shoulder, min	1/4	6	1/4	6	5/16	8
F—Diameter of shoulder	3/4 ± 1/64	16.0 ± 0.40	1 5/16 ± 1/64	24.0 ± 0.40	1 7/16 ± 1/64	36.5 ± 0.40

NOTE—The reduced section and shoulders (dimensions A, D, E, F, G, and R) shall be shown, but the ends may be of any form to fit the holders of the testing machine in such a way that the load shall be axial. Commonly the ends are threaded and have the dimensions B and C given above.

FIG. 6 Standard Tension Test Specimens for Cast Iron

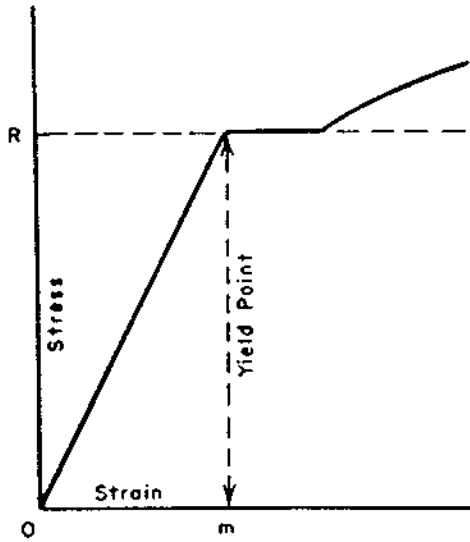

FIG. 7 Stress-Strain Diagram Showing Yield Point Corresponding with Top of Knee

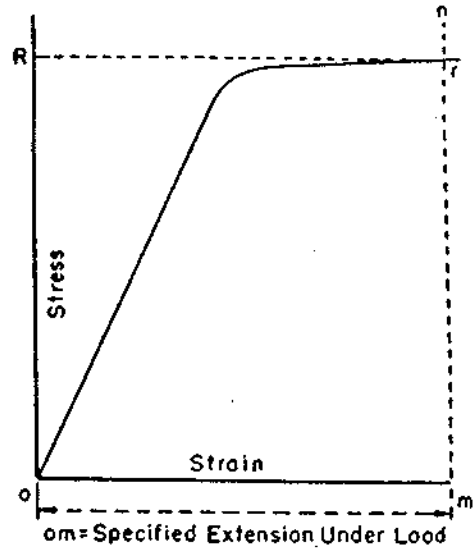

FIG. 8 Stress-Strain Diagram Showing Yield Point or Yield Strength by Extension Under Load Method

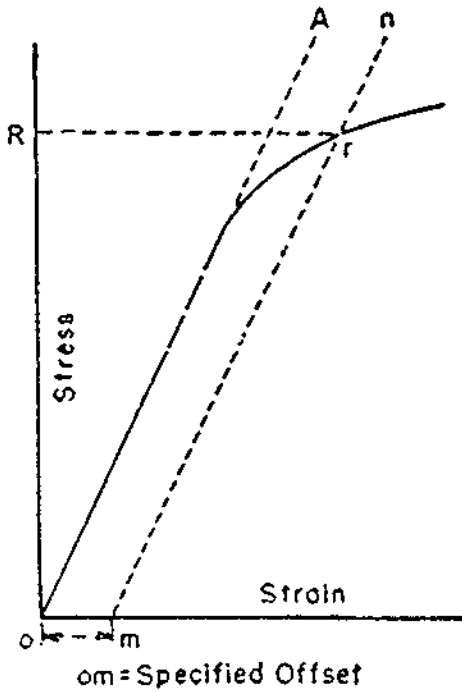
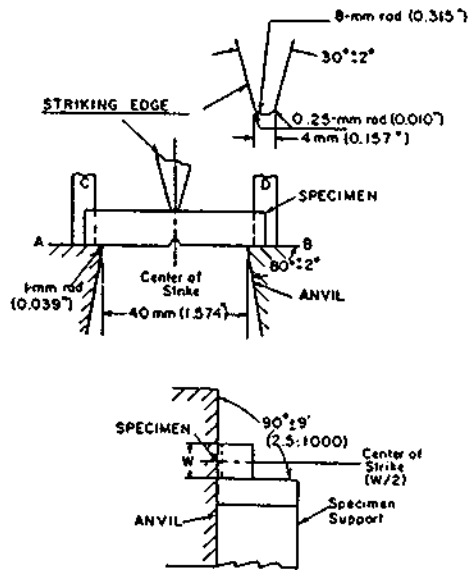

FIG. 9 Stress-Strain Diagram for Determination of Yield Strength by the Offset Method



All dimensional tolerances shall be ± 0.05 mm (0.002 in.) unless otherwise specified.

NOTE 1—A shall be parallel to B within 2:1000 and coplanar with B within 0.05 mm (0.002 in.).

NOTE 2—C shall be parallel to D within 20:1000 and coplanar with D within 0.125 mm (0.005 in.).

NOTE 3—Finish on unmarked parts shall be 4 μ m (125 μ in.).

FIG. 10 Charpy (Simple-Beam) Impact Test

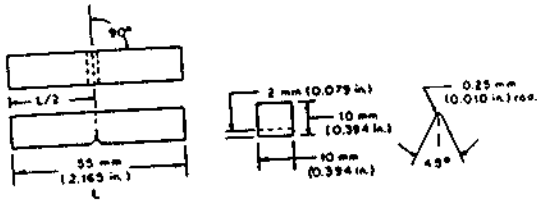

NOTE—Permissible variations shall be as follows:
 Adjacent sides shall be at
 Cross section dimensions
 Length of specimen
 Angle of notch
 Radius of notch
 Dimensions to bottom of notch:

90° ± 10 min
 ±0.025 mm (0.001 in.)
 +0, -2.5 mm (0.100 in.)
 ±1°
 ±0.025 mm (0.001 in.)
 8 ± 0.025 mm (0.315
 ± 0.001 in.)

Finish

63 μin. (1.6 μm) max on notched surface and
 opposite face; 125 μin. (3.2 μm) max on other
 two surfaces

(a) Standard Specimens

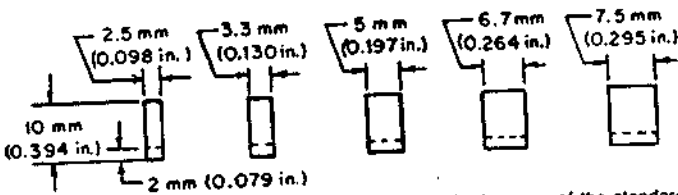

NOTE—On subsize specimens, all dimensions and tolerances of the standard
 specimen remain constant with the exception of the width, which varies as shown
 above.

(b) Subsize Specimens

FIG. 11 Charpy (Simple Beam) Impact Test Specimens

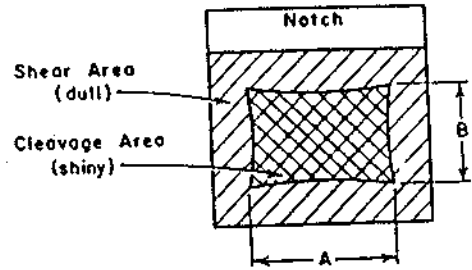

NOTE 1—Measure average dimensions A and B to the nearest 0.02 in. or 0.5 mm.

NOTE 2—Determine the percent shear fracture using Table 4 or Table 5.

FIG. 12 Determination of percent Shear Fracture



FIG. 13 Fracture Appearance Charts and Percent Shear Fracture Comparator

ASTM A 370

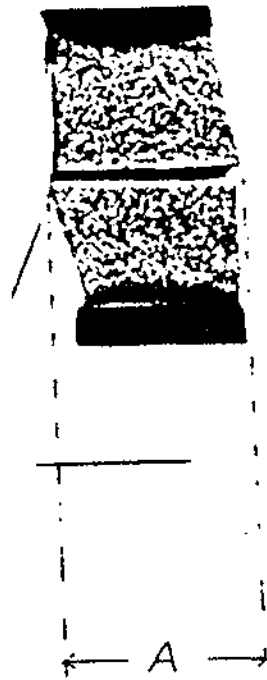

FIG. 14 Halves of Broken Charpy V-Notch Impact Specimen Joined for the Measurement of Lateral Expansion, Dimension A

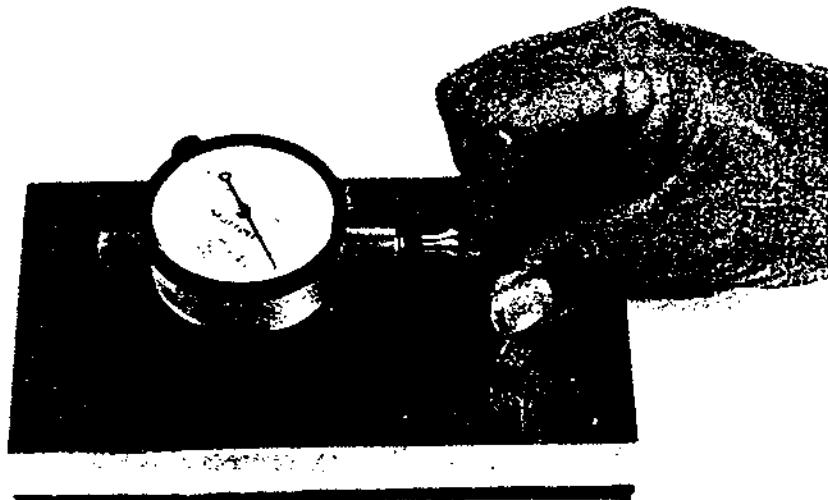

FIG. 15 Lateral Expansion Gage for Charpy Impact Specimens

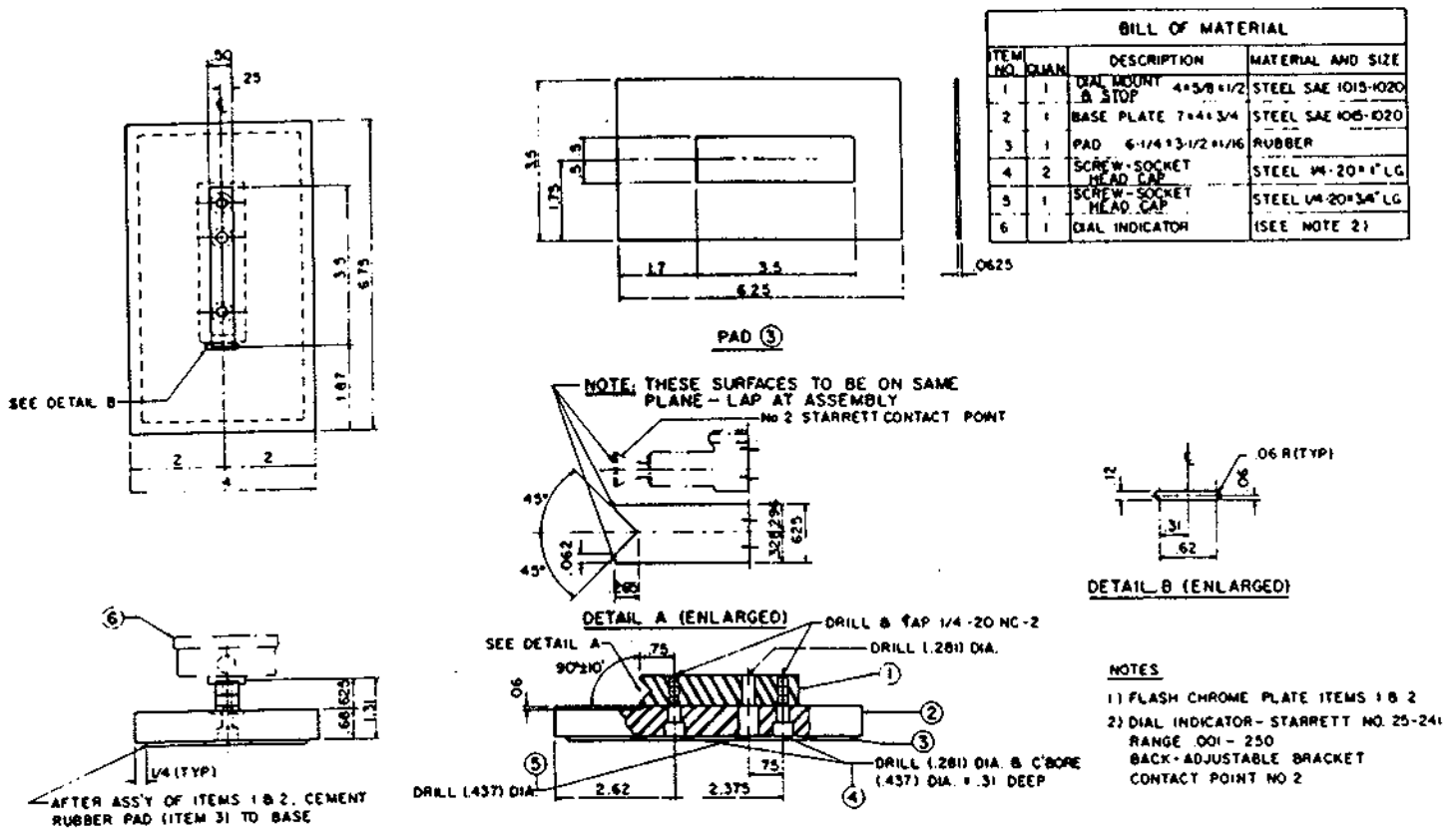

FIG. 16 Assembly and Details for Lateral Expansion Gauge

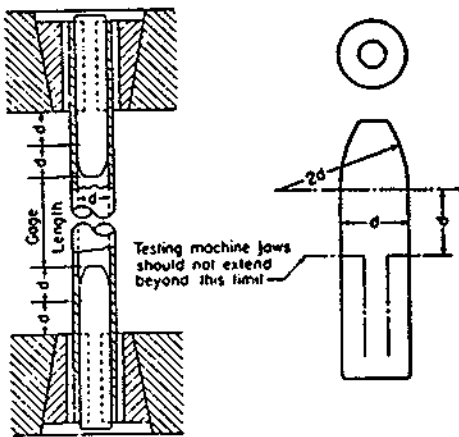
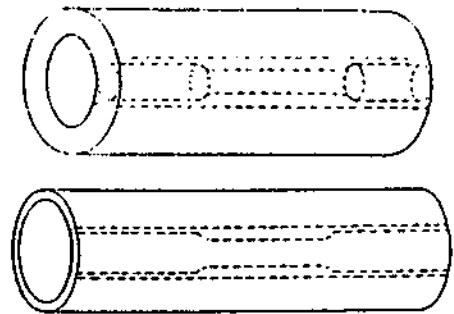

FIG. 17 Metal Plugs for Testing Tubular Specimens, Proper Location of Plugs in Specimen and of Specimen in Heads of Testing Machine



Note—The edges of the blank for the specimen shall be cut parallel to each other.

FIG. 18 Location of Strip Tension Test Specimens in Large Diameter Tubing

ASME A 370

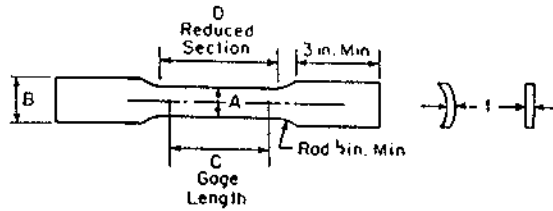

DIMENSIONS

Specimen No.	Dimensions, in.			
	A	B	C	D
1	$\frac{1}{2} \pm 0.015$	$1\frac{1}{8}$ approximately	2 ± 0.005	2¼ min
2	$\frac{3}{4} \pm 0.031$	1 approximately	2 ± 0.005	2¼ min
3	1 ± 0.062	$1\frac{1}{2}$ approximately	4 ± 0.005	4½ min
4	$1\frac{1}{2} \pm \frac{1}{8}$	2 approximately	2 ± 0.005	4½ min
			2 ± 0.010	2¼ min
			4 ± 0.015	4½ min
			6 ± 0.020	9 min

- NOTE 1—Cross-sectional area may be calculated by multiplying A and t.
 NOTE 2—The dimension t is the thickness of the test specimen as provided for in the applicable material specifications.
 NOTE 3—The reduced section shall be parallel within 0.010 in. and may have a gradual taper in width from the ends toward the center, with the ends not more than 0.010 in. wider than the center.
 NOTE 4—The ends of the specimen shall be symmetrical with the center line of the reduced section within 0.10 in.
 NOTE 5—Metric equivalent: 1 in. = 25.4 mm.
 NOTE 6—Specimens with sides parallel throughout their length are permitted, except for referee testing, provided: (a) the above tolerances are used; (b) an adequate number of marks are provided for determination of elongation; and (c) when yield strength is determined, a suitable extensometer is used. If the fracture occurs at a distance of less than 2W from the edge of the gripping device, the tensile properties determined may not be representative of the material. If the properties meet the minimum requirements specified, no further testing is required, but if they are less than the minimum requirements, discard the test and retest.

FIG. 19 Dimensions and Tolerances for Strip Tension Test Specimens for Large Diameter Tubing

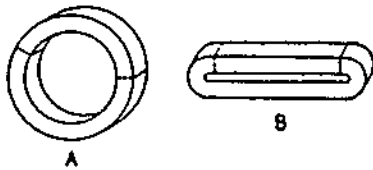
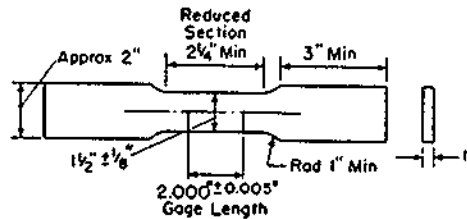

FIG. 20 Location of Transverse Tension Test Specimens in Ring Cut from Tubular Products.



- NOTE 1—The dimension t is the thickness of the test specimen as provided for in the applicable material specifications.
 NOTE 2—The reduced section shall be parallel within 0.010 in. and may have a gradual taper in width from the ends toward the center, with the ends not more than 0.010 in. wider than the center.
 NOTE 3—The ends of the specimen shall be symmetrical with the center line of the reduced section within 0.10 in.
 NOTE 4—Metric equivalent: 1 in. = 25.4 mm.

FIG. 21 Transverse Tension Test Specimen Machined from Ring Cut from Tubular Products

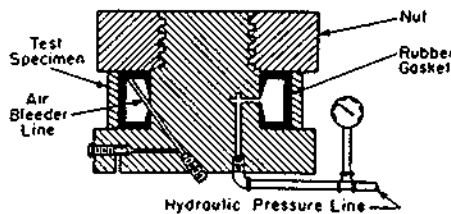

FIG. 22 Testing Machine for Determination of Transverse Yield Strength from Annular Ring Specimens

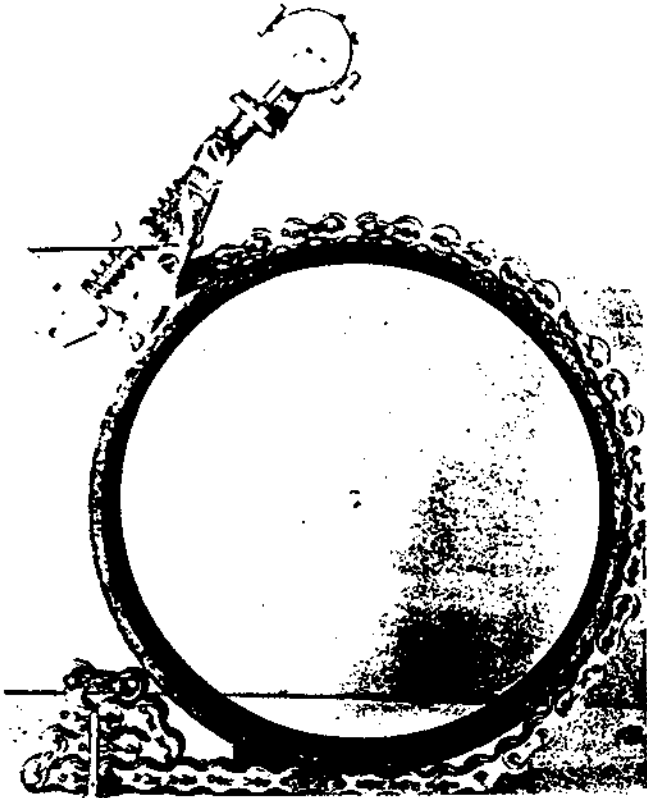

FIG. 23 Roller Chain Type Extensometer, Unclamped

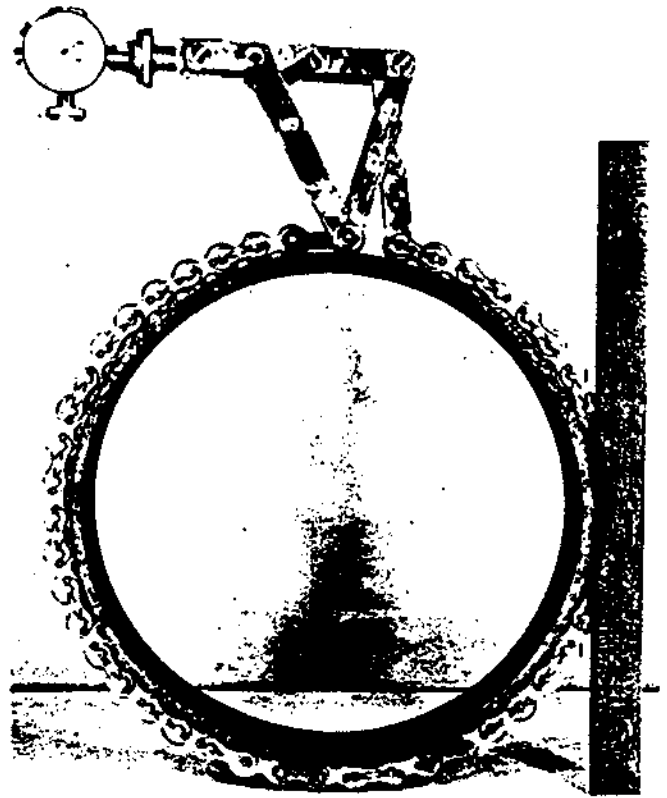

FIG. 24 Roller Chain Type Extensometer, Clamped

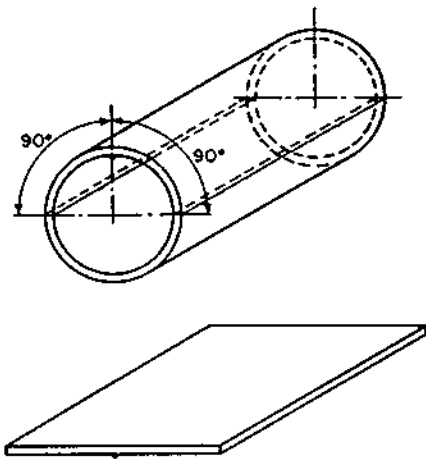

FIG. 25 Reverse Flattening Test

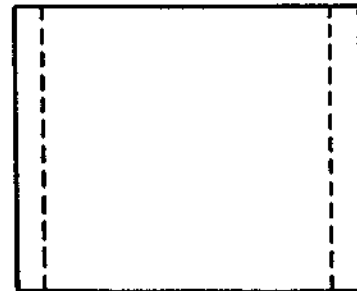
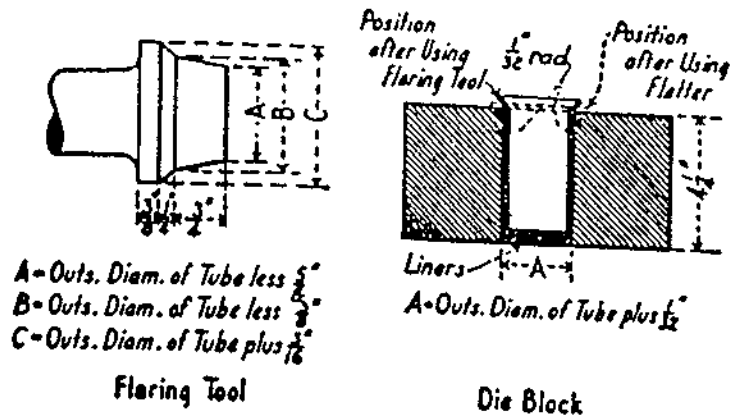

FIG. 26 Crush Test Specimen



NOTE—Metric equivalent: 1 in. = 25.4 mm.

FIG. 27 Flaring Tool and Die Block for Flange Test

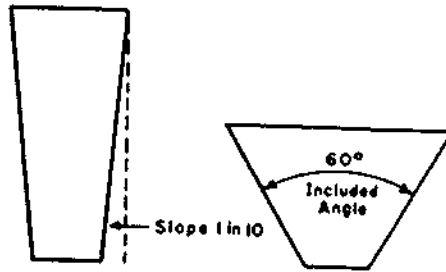
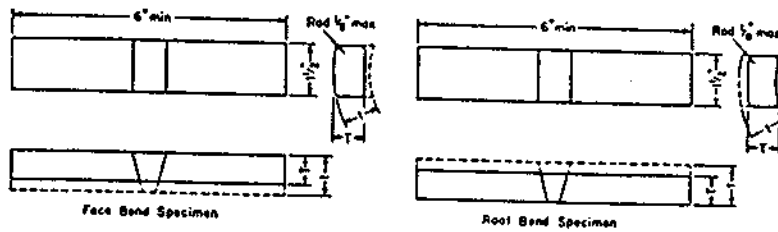

FIG. 28 Tapered Mandrels for Flaring Test



NOTE—Metric equivalent: 1 in. = 25.4 mm.

Pipe Wall Thickness (t), in.	Test Specimen Thickness, in.
Up to 3/8, incl	t
Over 3/8	3/8

FIG. 29(a) Transverse Face- and Root-Bend Test Specimens

A 370

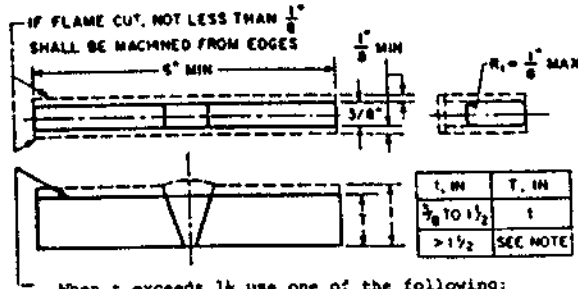

- When t exceeds $1\frac{1}{4}$ use one of the following:
1. Cut along line indicated by arrow. Edge may be flame cut and may or may not be machined.
 2. Specimens may be cut into approximately equal strips between $\frac{3}{4}$ in. and $1\frac{1}{4}$ in. wide for testing or the specimens may be bent at full width (see requirements on jig width in Fig. 32)

NOTE—Metric equivalent: 1 in. = 25.4 mm.

FIG. 29(b) Side-Bend Specimen for Ferrous Materials

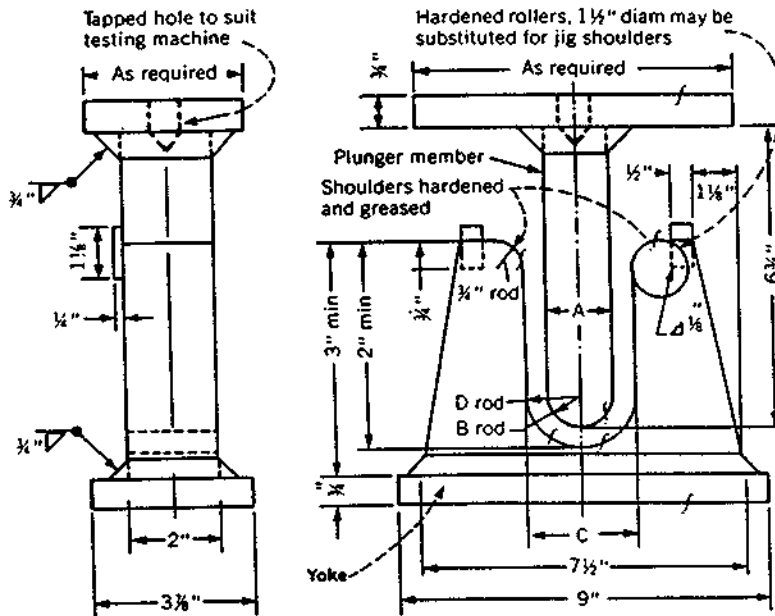

NOTE: Metric equivalent: 1 in. = 25.4 mm.

Test Specimen Thickness, in.	A	B	C	D	Material
$\frac{3}{8}$	$1\frac{1}{2}$	$\frac{3}{4}$	$2\frac{3}{8}$	$1\frac{1}{16}$	Materials with a specified minimum tensile strength of 95 ksi or greater.
t	$4t$	$2t$	$6t + \frac{1}{8}$	$3t + \frac{1}{16}$	

FIG. 30 Guided-Bend Test Jig

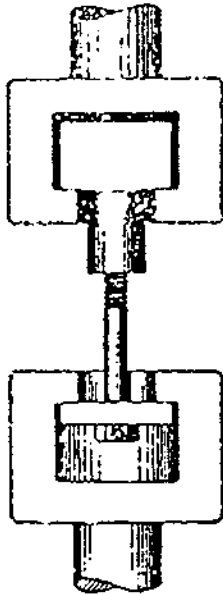
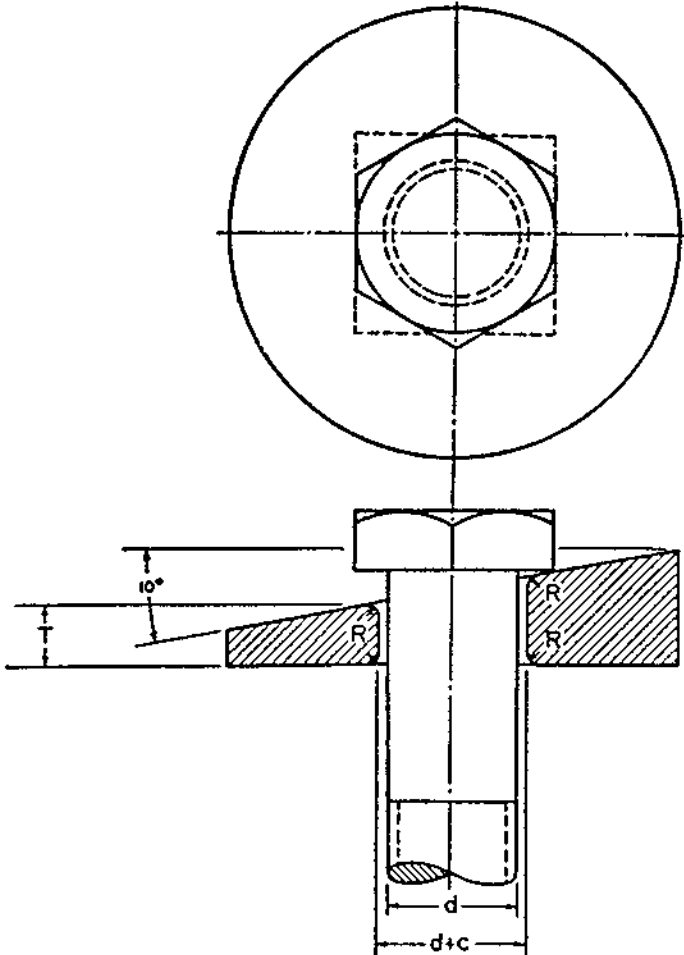
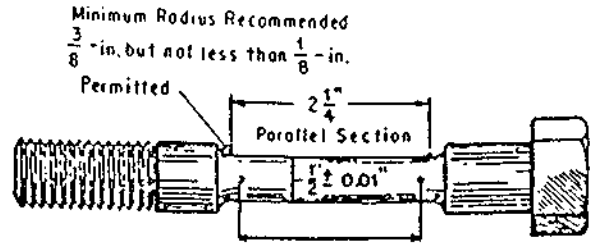

FIG. 31 Tension Testing Full-Size Bolt



c = Clearance of wedge hole
 d = Diameter of bolt
 R = Radius
 T = Thickness of wedge at short side of hole equal to one-half diameter of bolt

FIG. 32 Wedge Test Detail



$2" \pm 0.005"$ Gage Length for Elongation after Fracture

NOTE—Metric equivalent: 1 in. = 25.4 mm.

FIG. 33 Tension Test Specimen for Bolt with Turned-Down Shank

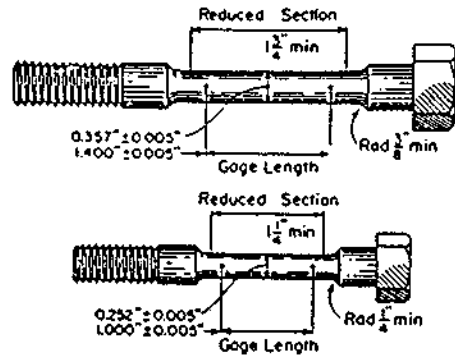

NOTE—Metric equivalent: 1 in. = 25.4 mm.

FIG. 34 Examples of Small Size Specimens Proportional to Standard 2-in. Gage Length Specimen

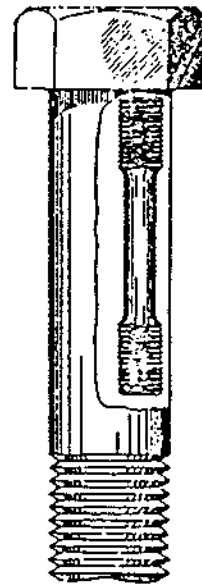

FIG. 35 Location of Standard Round 2-in. Gage Length Tension Test Specimen When Turned from Large Size Bolt

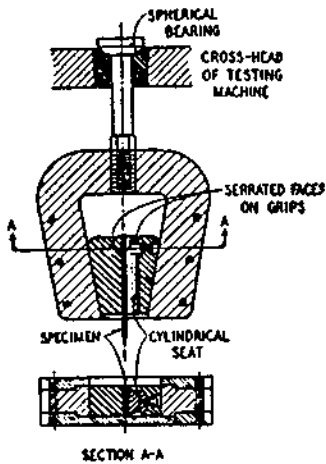

FIG. 36 Wedge-Type Gripping Device

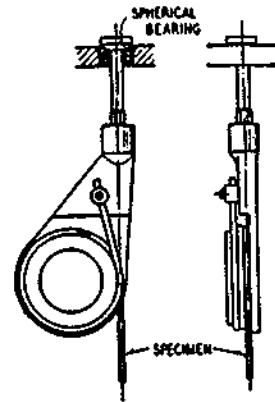

FIG. 37 Snubbing-Type Gripping Device

The American Society for Testing and Materials takes no position respecting the validity of any patent rights asserted in connection with any item mentioned in this standard. Users of this standard are expressly advised that determination of the validity of any such patent rights, and the risk of infringement of such rights, are entirely their own responsibility.

This standard is subject to revision at any time by the responsible technical committee and must be reviewed every five years and if not revised, either reapproved or withdrawn. Your comments are invited either for revision of this standard or for additional standards and should be addressed to ASTM Headquarters. Your comments will receive careful consideration at a meeting of the responsible technical committee, which you may attend. If you feel that your comments have not received a fair hearing you should make your views known to the ASTM Committee on Standards, 1916 Race St., Philadelphia, PA 19103.